

TYPE A

Ref.: 156269



ISO/PAS 11154



CITY CRASH TEST



n° 269



Peugeot 1007

5

04/2004->03/2009

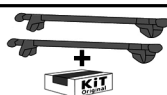

5 kg + xx Kg = 75 kg max

Ne pas dépasser la charge maximale des barres. Ne pas dépasser la charge maximale indiquée par le constructeur du véhicule

Non superare il carico massimo delle barre portatutto. Non superare il carico massimo indicato dal costruttore del veicolo

Carga máxima admisible indicada en la caja de las barras de techo. No exceda la carga máxima permitida por el fabricante del vehículo.

Maximum allowable load indicated on the box of roof bars. Do not exceed the maximum load allowed by the vehicle manufacturer.

Maximal zulässige belastung angegeben auf der box der dachreling. Überschreiten sie nicht die maximale belastung durch den fahrzeughersteller zugelassen.

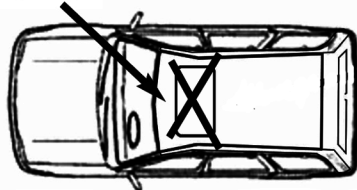
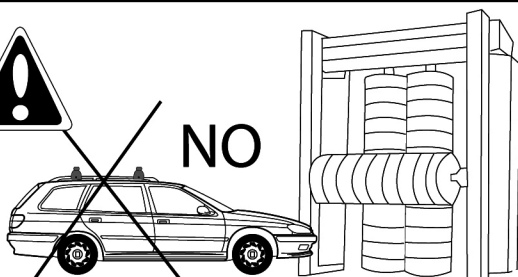
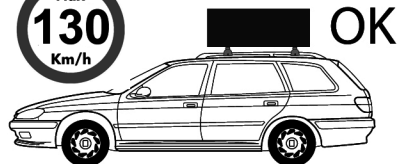
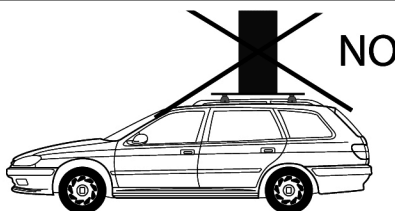
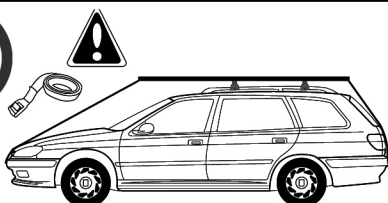
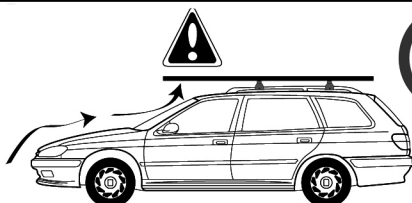

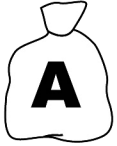

M6x50

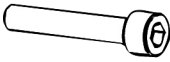

4762.650
x4

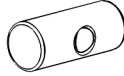

162100001
x4



659106
x4



100005
x1

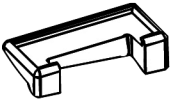

x1
1122601

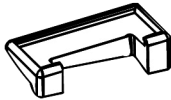

x1
1122602

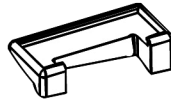

x1
1122603

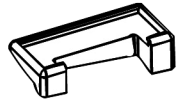

x1
1122604

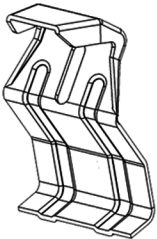

238A
x1

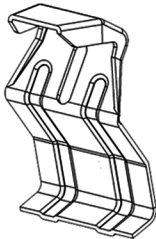

238B
x1

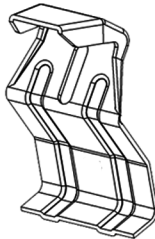

238CD
x2

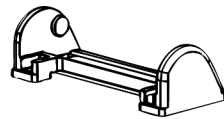

x4
214800001



	X	Y
Peugeot 1007	94,5 cm	91 cm

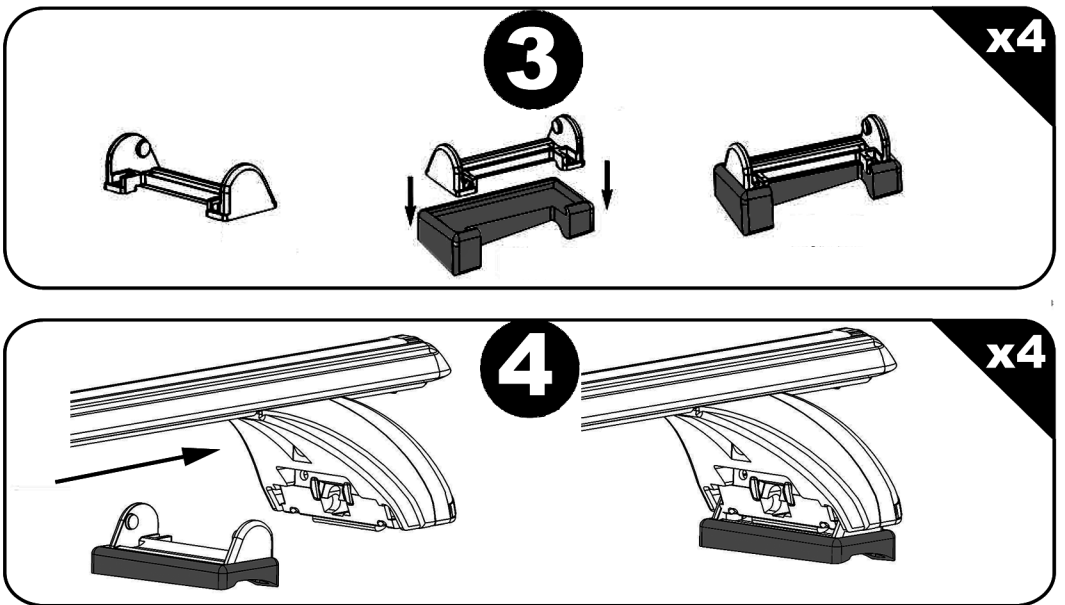
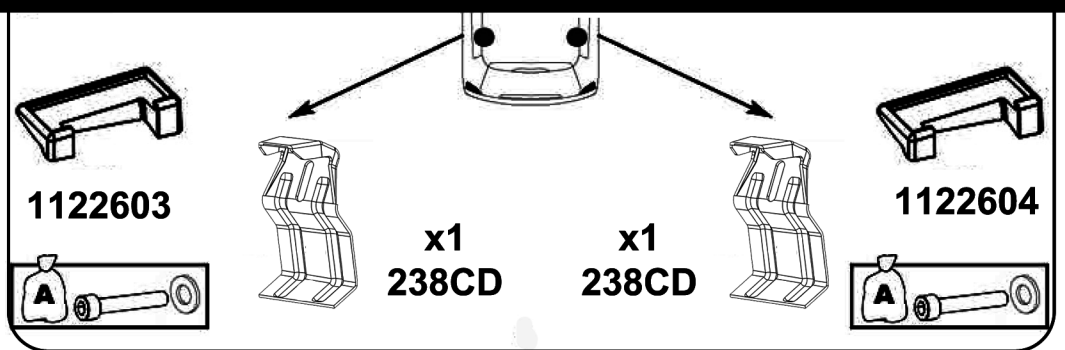
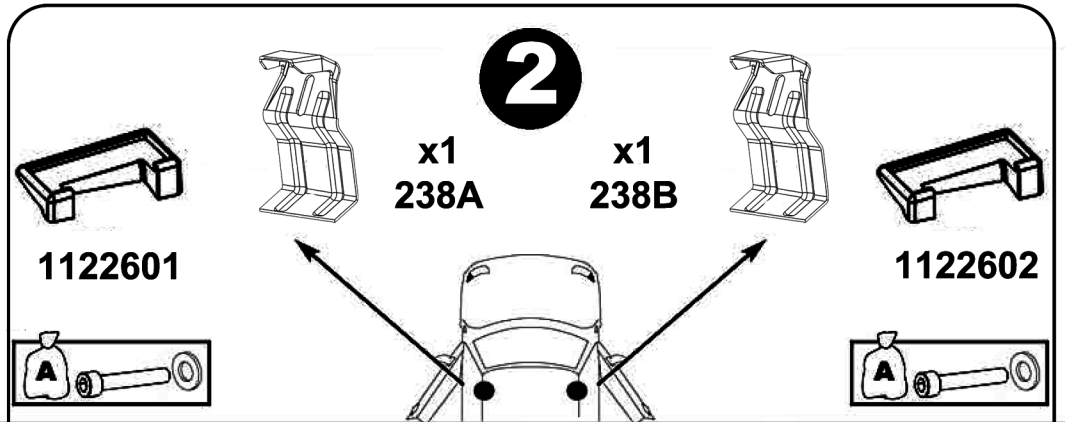

5

x4

A)

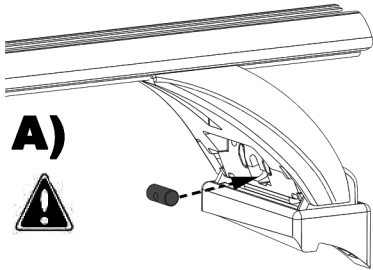

B)

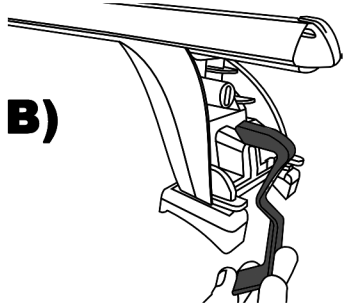

C)

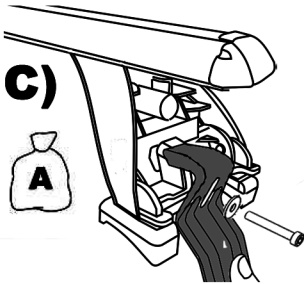

D)

x2

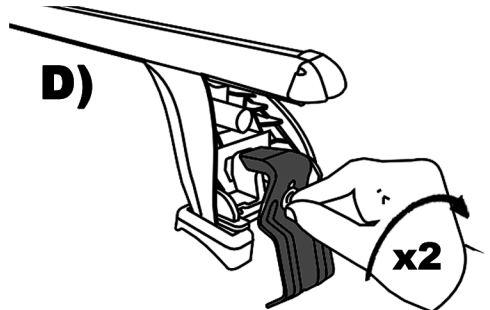

6

x2

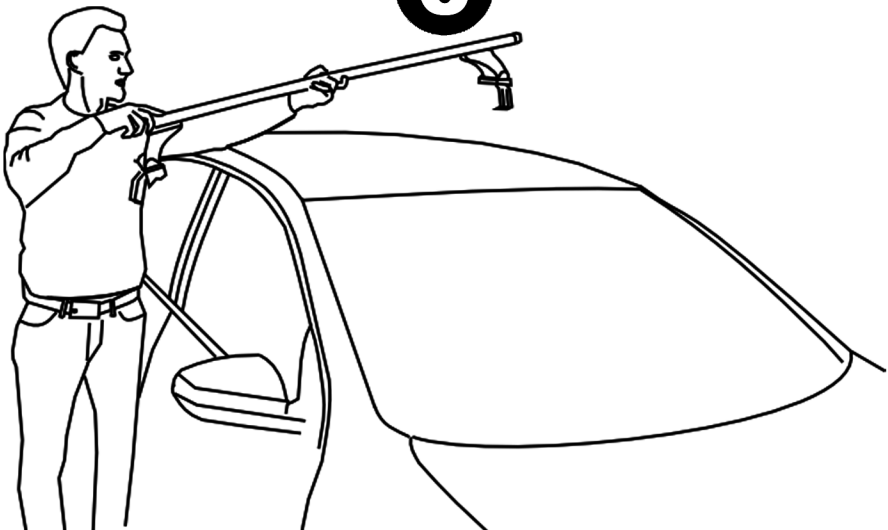

7

61 Cm

13 Cm

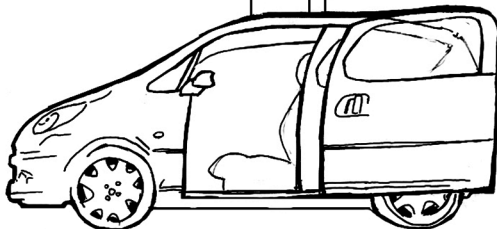

x4

A)

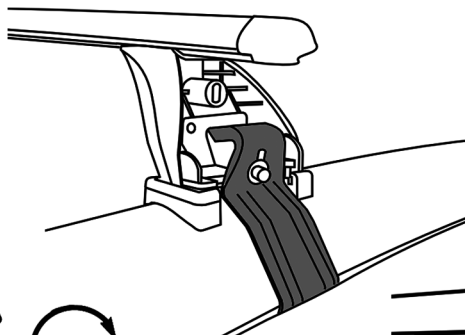

6Nm

B)

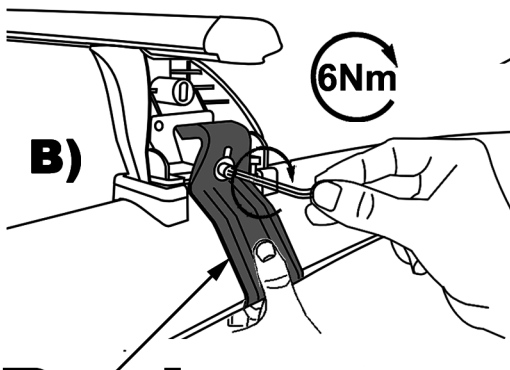

C)

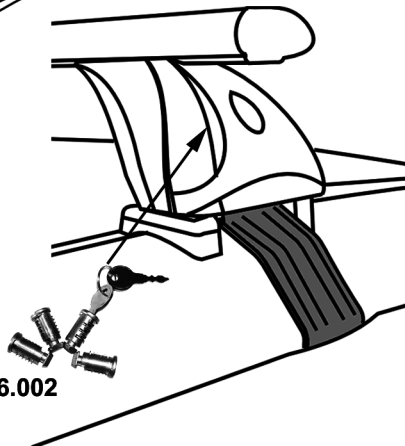

Push

OPTION 156.002

F Serrer alternativement chaque côté
E Alternare il serraggio delle viti
I Serrare alternativamente
P Aperte alternadamente
GB Tighten alternately
D Die Schrauben abwechselnd anziehen

NL Afwisselend aan de linker en de rechterkant aandraaien
S Dra åt växelvis
FIN Kierrä vuorotellen
EST Pinguldage vaheldumisi
LAT Pievelciēt pamāšus
LIT Uzsukinkite pakaitomis
PL Sruby dokrecaj naprzemiennie

CZ Pokretla bagaznika dokrecaj dokrecaj naprzemiennie
SK Dotahujte striedavo
SLO Privijajte izmenicno
HR Naizmjenicno zategnite
HU Egymástól függetlenül szorítandó
TR Dönüşümlü sıkın

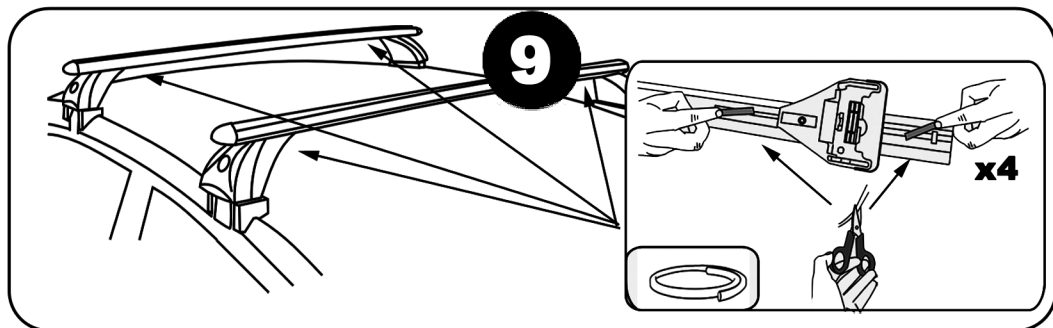
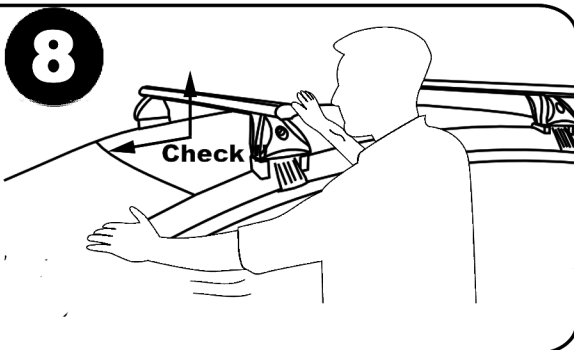
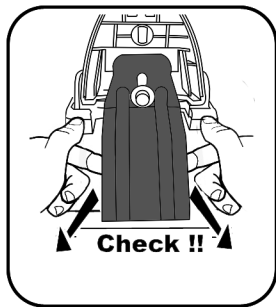

Démontage - Desmontaje - Smontaggio - Desmontagem - Disassembly - Demontage

