

TYPE F

Ref.: 156.407



ISO/PAS 11154



CITY CRASH TEST



n°407



Opel Insigna (J) s.w (with railing)

5

08-2008>



5 kg + xx Kg = 75kg max

Charge maximale admissible indiquée sur la boîte des barres de toit .Ne pas dépasser la charge maximale autorisée par le constructeur du véhicule
Il Carico massimo ammissibile è indicato sulla scatola delle barre. Non superare il carico massimo consentito dal costruttore del veicolo
Carga máxima admisible indicada en la caja de las barras de techo. No exceda la carga máxima permitida por el fabricante del vehículo.
Maximum allowable load indicated on the box of roof bars. Do not exceed the maximum load allowed by the vehicle manufacturer.
Maximal zulässige belastung angegeben auf der box der dachreling. Überschreiten sie nicht die maximale belastung durch den fahrzeughersteller zugelassen.

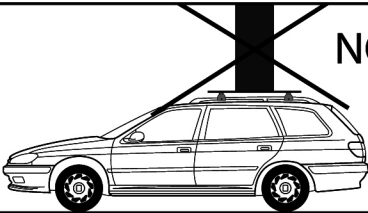
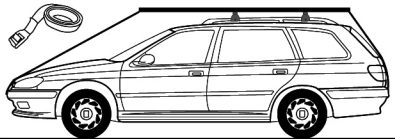
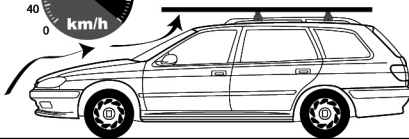

NO

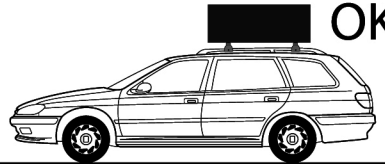

OK

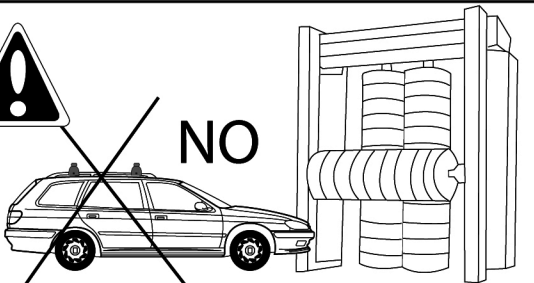

NO

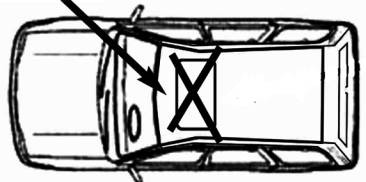



M6x20
x4



5588.06
x4



6592.06
x4



100005
X1

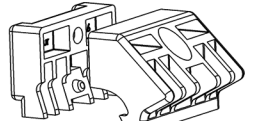

1640707
x4

1740707
x4

1

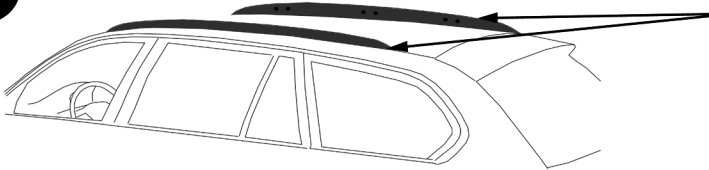

2

1)

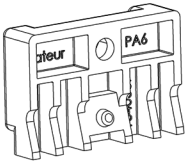

2)

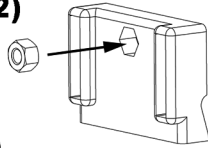

3)

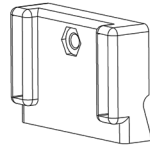

x4

3

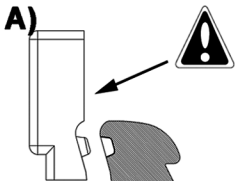
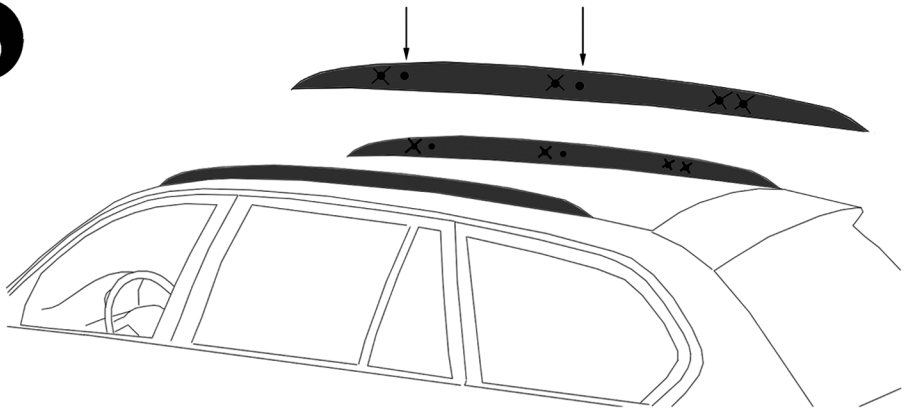

x4

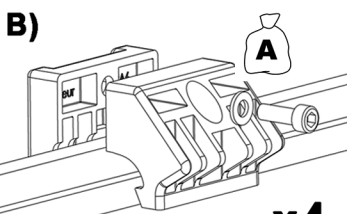

x4

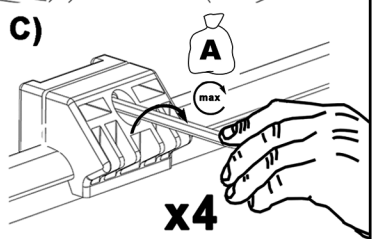

x4

4

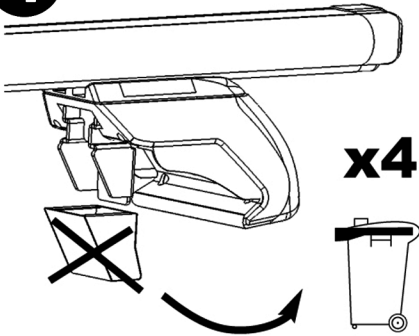

5

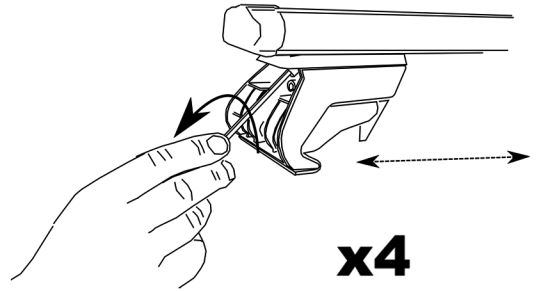

6

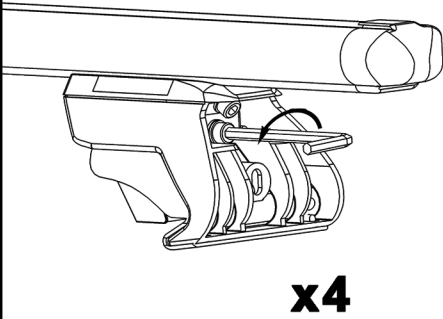

7

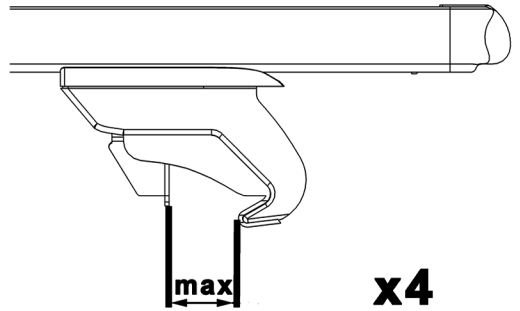

8

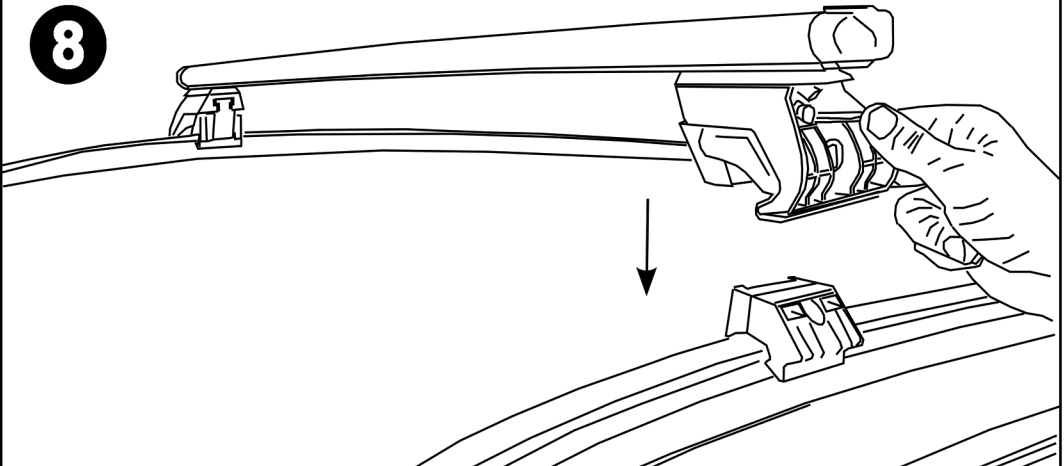

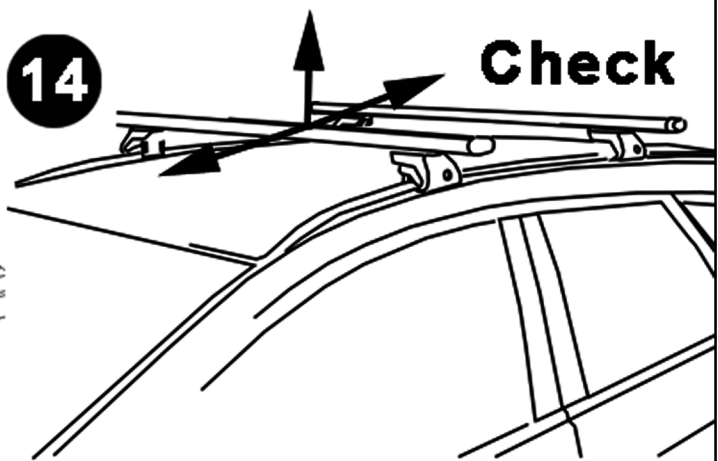
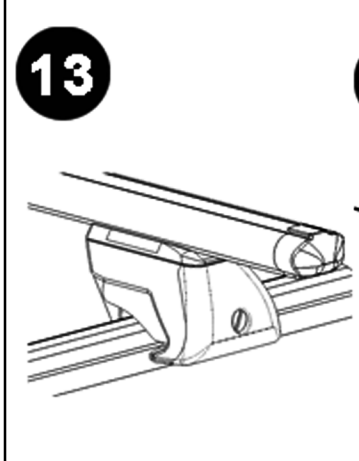
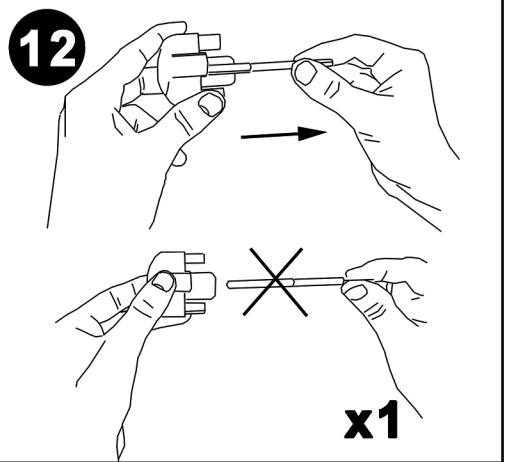
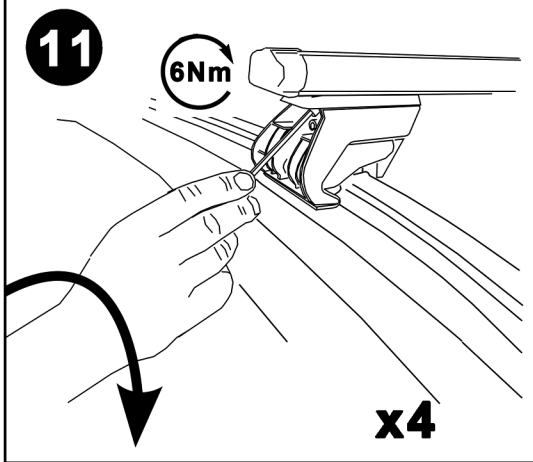
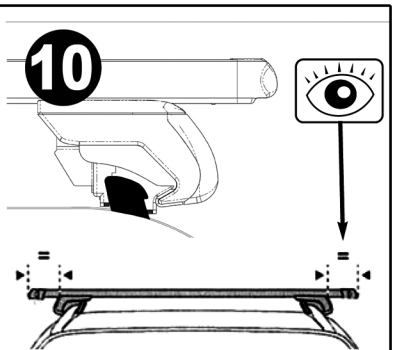
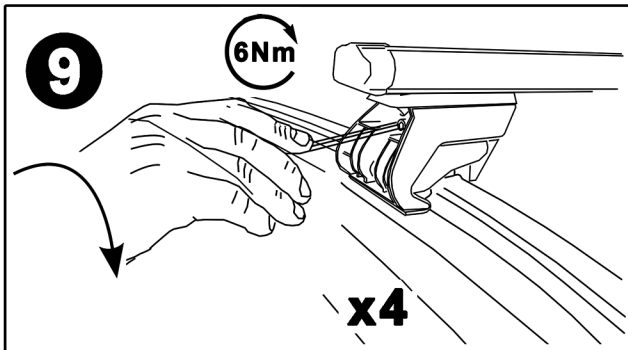

MG-MG-09/11 -11100407