

**TYPE F**

**Ref.: 156.408**



ISO/PAS 11154



CITY CRASH TEST



**n° 408**



**BMW Serie 3 E90 s.w (with railing)**

**5**

**01-2011 >**

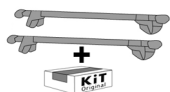

**5 kg + xx Kg = 75 kg max**

Charge maximale admissible indiquée sur la boîte des barres de toit. Ne pas dépasser la charge maximale autorisée par le constructeur du véhicule.  
Il Carico massimo ammissibile è indicato sulla scatola delle barre. Non superare il carico massimo consentito dal costruttore del veicolo.  
Carga máxima admisible indicada en la caja de las barras de techo. No exceda la carga máxima permitida por el fabricante del vehículo.  
Maximum allowable load indicated on the box of roof bars. Do not exceed the maximum load allowed by the vehicle manufacturer.  
Maximal zulässige Belastung angegeben auf der Box der Dachreling. Überschreiten Sie nicht die maximale Belastung durch den Fahrzeughersteller zugelassen.

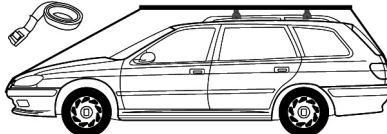
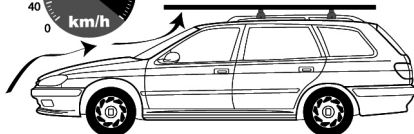

**NO**



**OK**

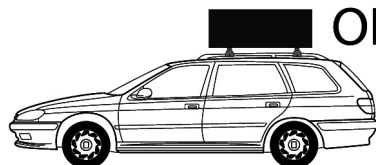

**NO**

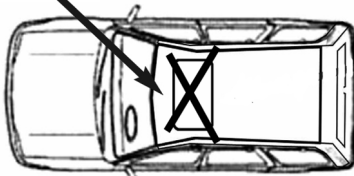
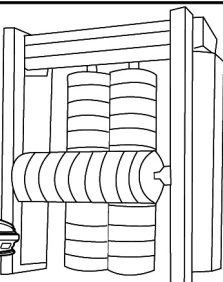
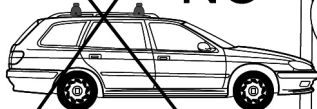



M6x20  
x4



5588.06  
x4



6592.06  
x4



100005  
x1

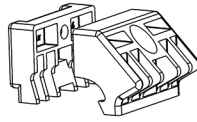

1640807  
x4

1740807  
x4



3540827  
x4

**1**

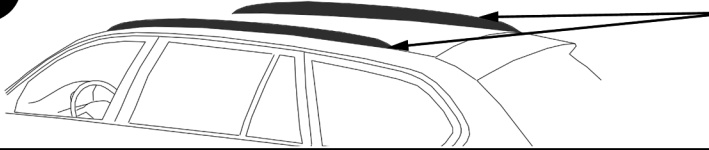

**2**

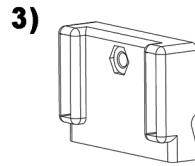
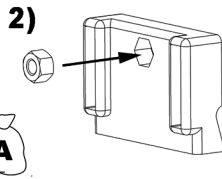
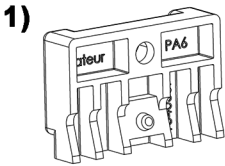

x4

**3**

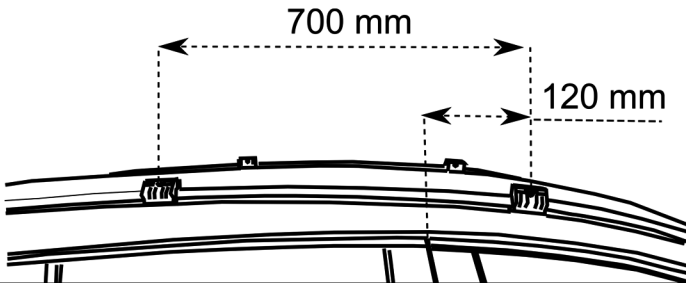

**4**

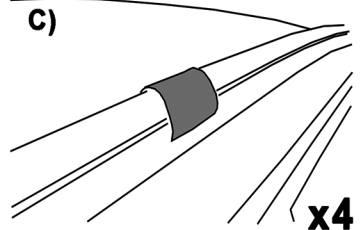
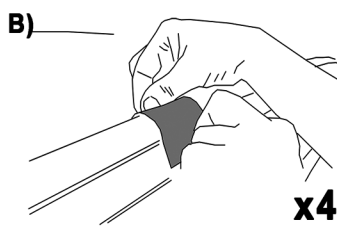
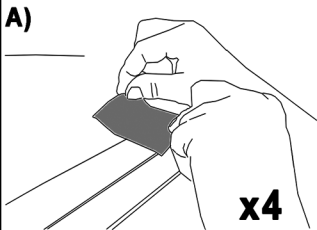

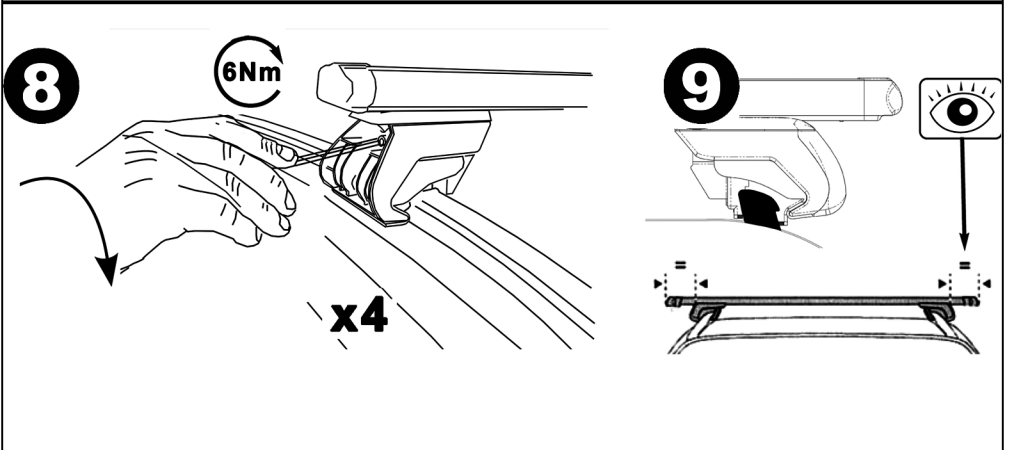
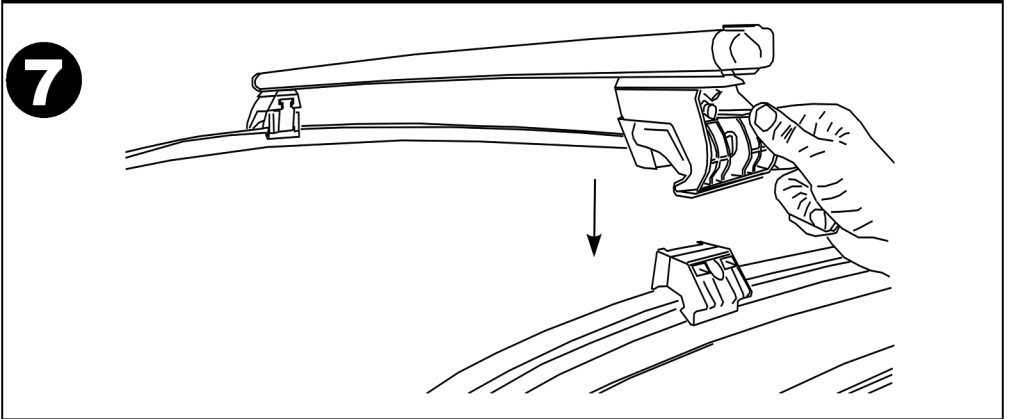
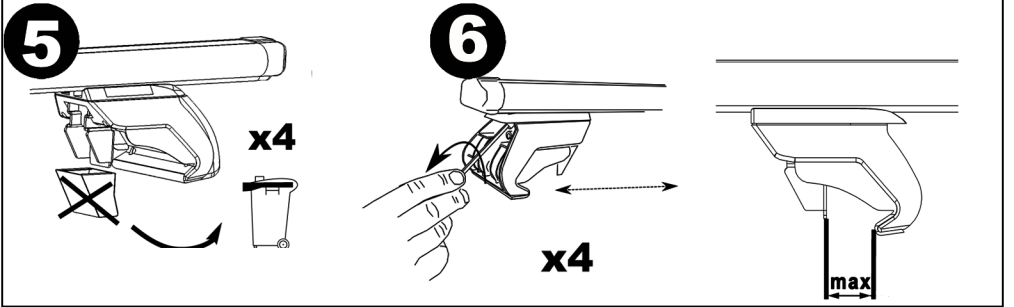
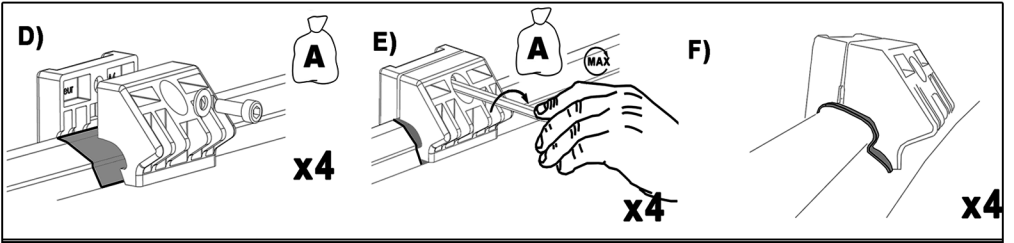

**10**

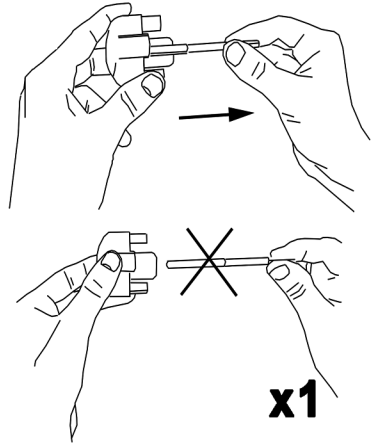
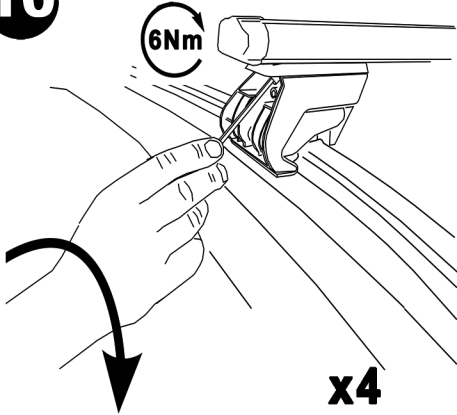

**11**

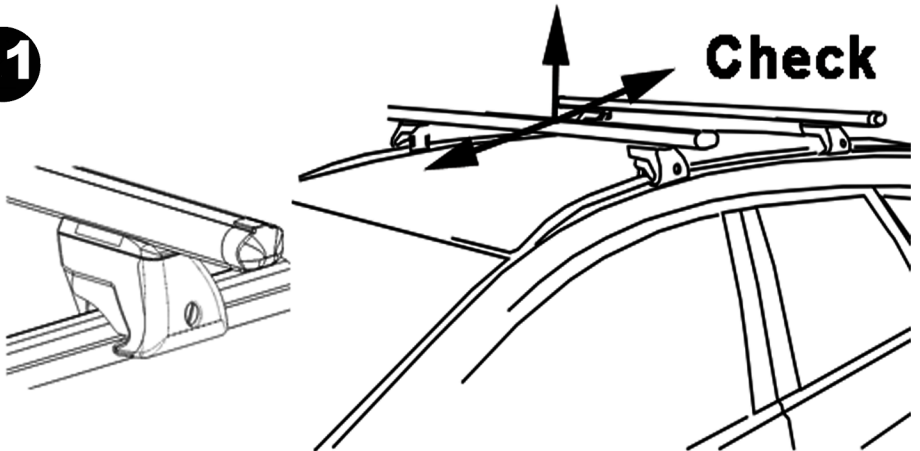

**MG-MG-09/11 -11100408**