

K426

Fitting Kit

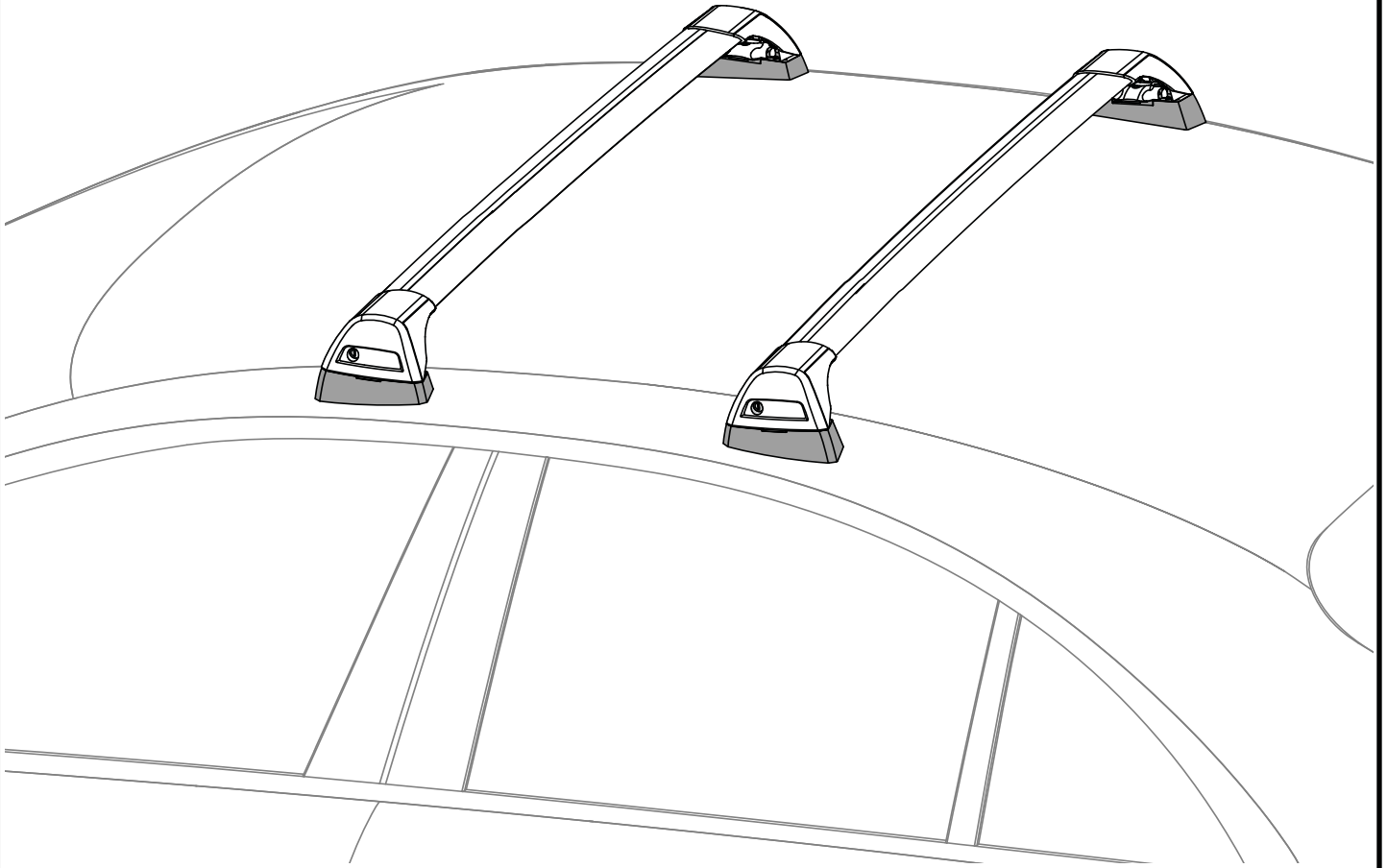

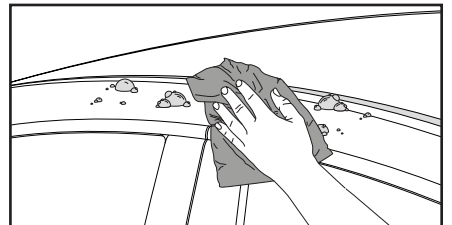

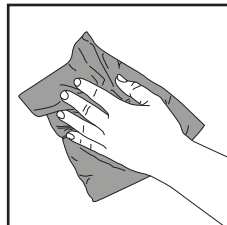
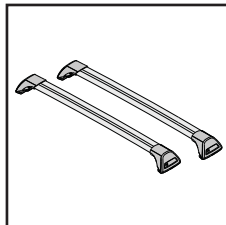
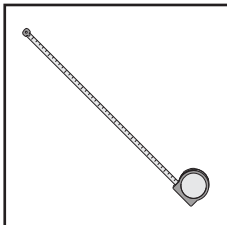
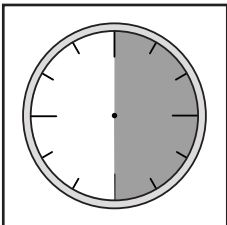

**REQUIRED • ERFORDERLICH • REQUERIDOS • OBLIGATOIRE • NØDVENDIG • NECESSÁRIO
ОБЯЗАТЕЛЬНО • OBBLIGATORIO • POTRZEBY • NEVYHNUTELNÉ • NEVYHNUTNÉ • NODIG • NØDVÄNDIG**

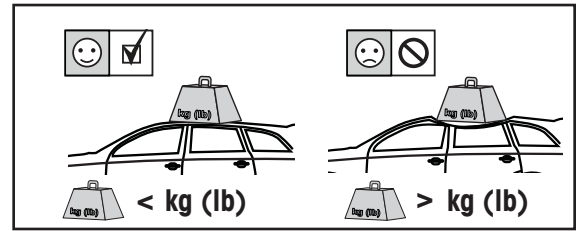
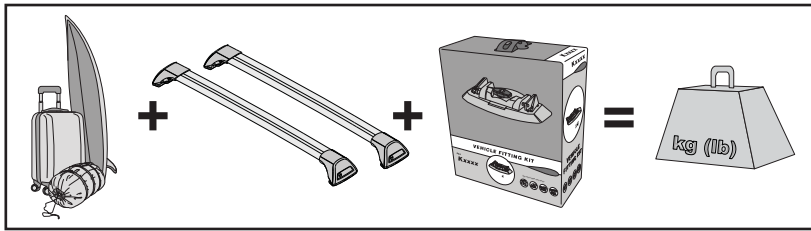

**MAXIMUM kg (lb) • MAXIMUM kg • MÁXIMO kg • MAXIMUM kg • MAKSIMALT kg • MÁXIMO kg
 МАКСИМУМ кг • MASSIMO kg • MAKSIMALNEJ kg • MAXIMÁLNÍ kg • MAXIMÁLNE kg
 MAXIMUM kg • MAXIMAL kg**

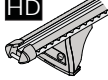

		F  T  P 	HD 
Holden Commodore VE, 4dr Sedan Aug 06-May 13	AU	75 kg (165 lb)	75 kg (165 lb)
Holden Commodore VE, 4dr Sedan Sep 06-May 13	NZ	75 kg (165 lb)	75 kg (165 lb)
Holden Commodore VE, 5dr Wagon Apr 08-May 13	AU	75 kg (165 lb)	75 kg (165 lb)
Holden Commodore VE, 5dr Wagon Jul 08-May 13	NZ	75 kg (165 lb)	75 kg (165 lb)
Holden Commodore VF, 4dr Sedan Jun 13-Mar 17	AU, NZ	75 kg (165 lb)	75 kg (165 lb)
Holden Commodore VF II, 4dr Sedan Apr 17-Feb 18	AU	75 kg (165 lb)	75 kg (165 lb)
Holden Commodore VF II, 4dr Sedan Apr 17-18	NZ	75 kg (165 lb)	75 kg (165 lb)
Holden Commodore VF, 5dr Wagon Jun 13 -Mar 17	AU, NZ	75 kg (165 lb)	75 kg (165 lb)
Holden Commodore VF II, 5dr Wagon Apr 17-Feb 18	AU	75 kg (165 lb)	75 kg (165 lb)
Holden Commodore VF II, 5dr Wagon Apr 17-18	NZ	75 kg (165 lb)	75 kg (165 lb)

**CONTENTS • INHALT • CONTENIDO • CONTENU • INNHOLD • CONTEÚDO • СОДЕРЖАНИЕ • CONTENUTO
ZAWARTOŚĆ • OBSAH • OBSAH • INHOUD • INNEHÅLL**

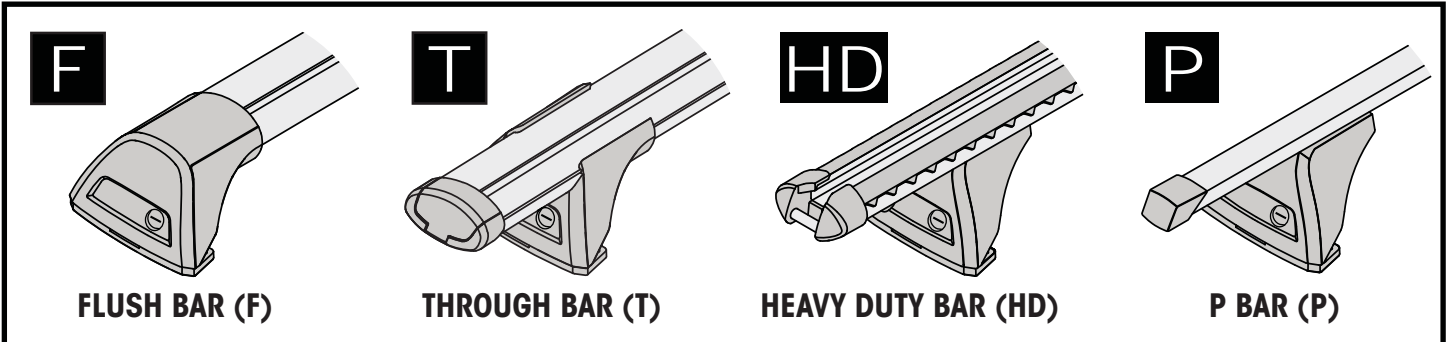
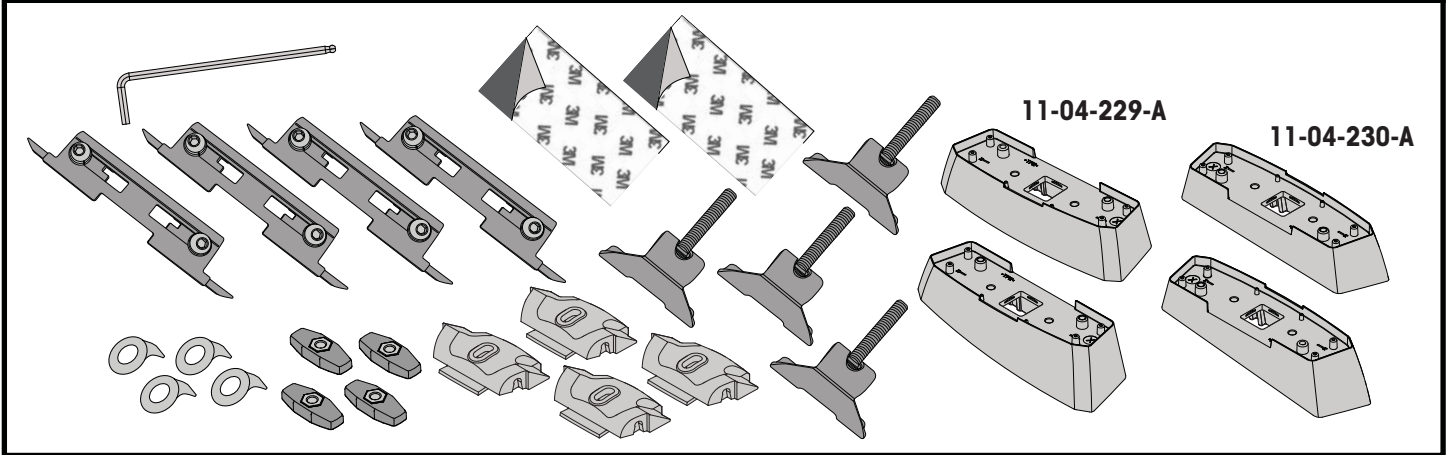

**ATTENTION • ACHTUNG • ATENCIÓN • ATTENTION • OPPMERKSOMHET • ATENÇÃO • ВНИМАНИЕ
ATTENZIONE • UWAGA • UPOZORNĚNÍ • UPOZORNENIE • LET OP • UPPMÄRKSAMHET**

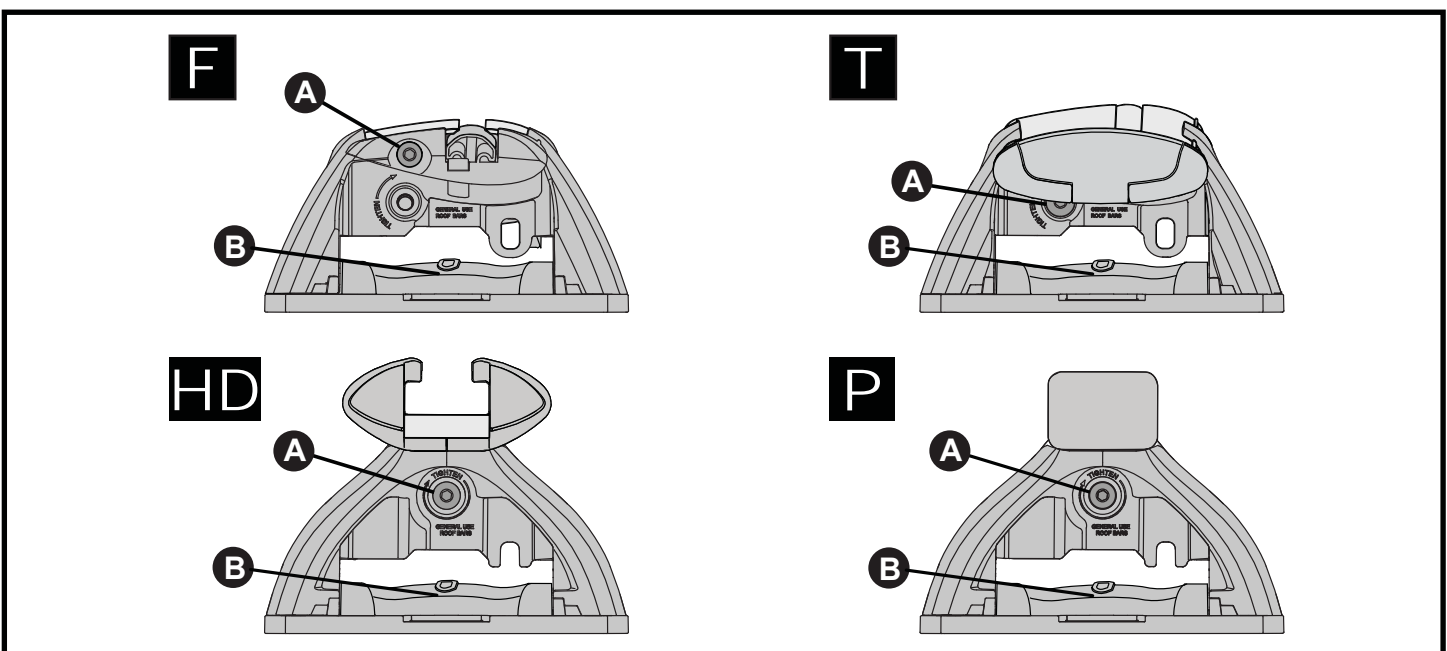
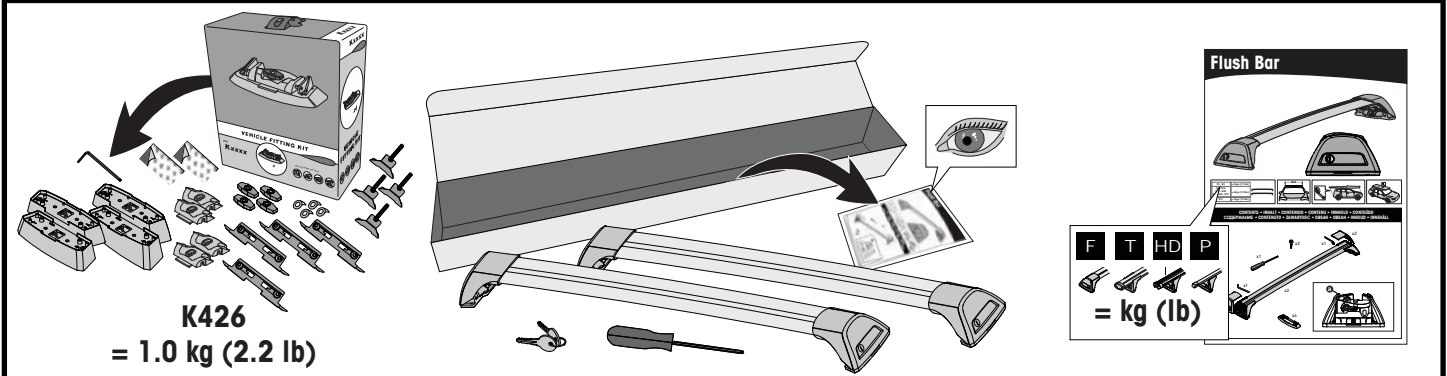

ATTENTION • ACHTUNG • ATENCIÓN • ATTENTION • OPPMERKSOMHET • ATENÇÃO • ВНИМАНИЕ
 ATTENZIONE • UWAGA • UPOZORNĚNÍ • UPOZORNENIE • LET OP • UPPMÄRKSAMHET

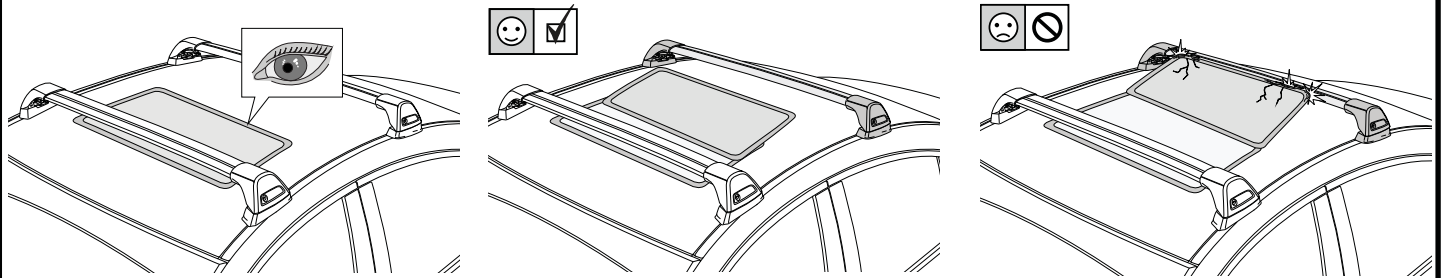

1

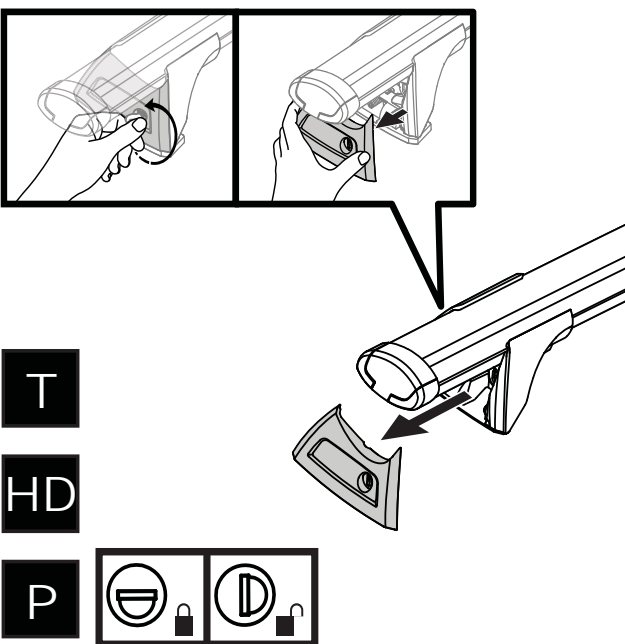
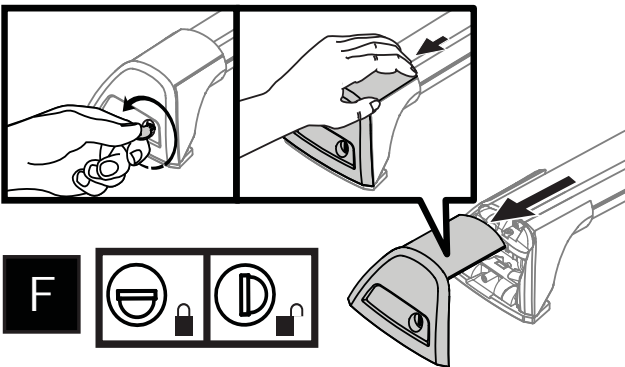

x4

2

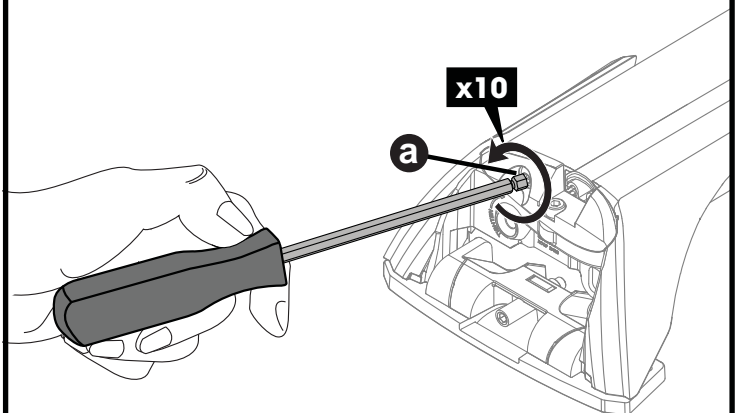
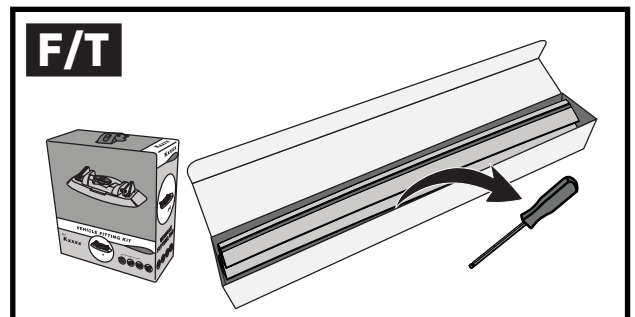
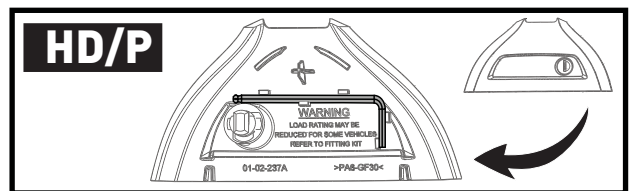

x4

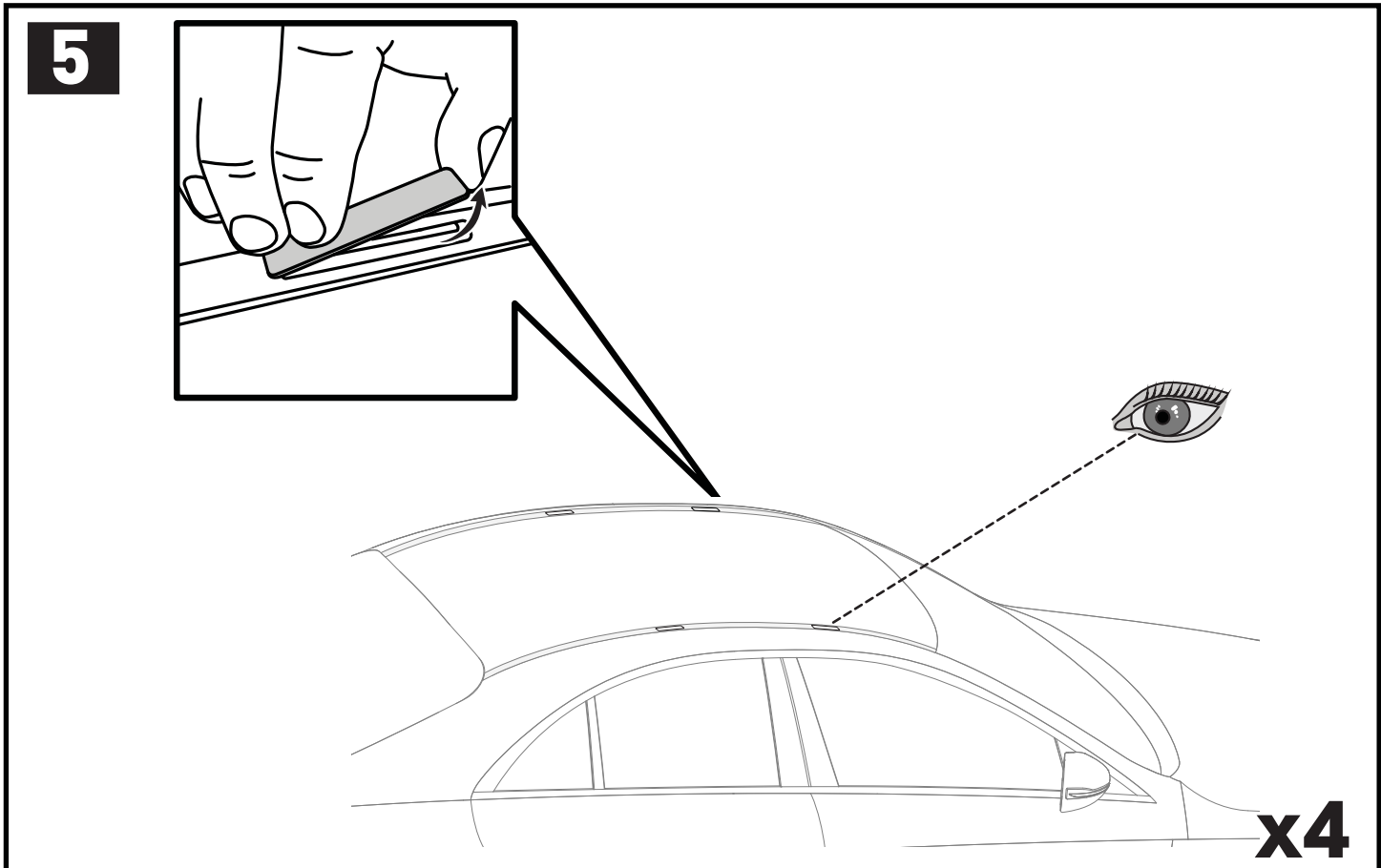
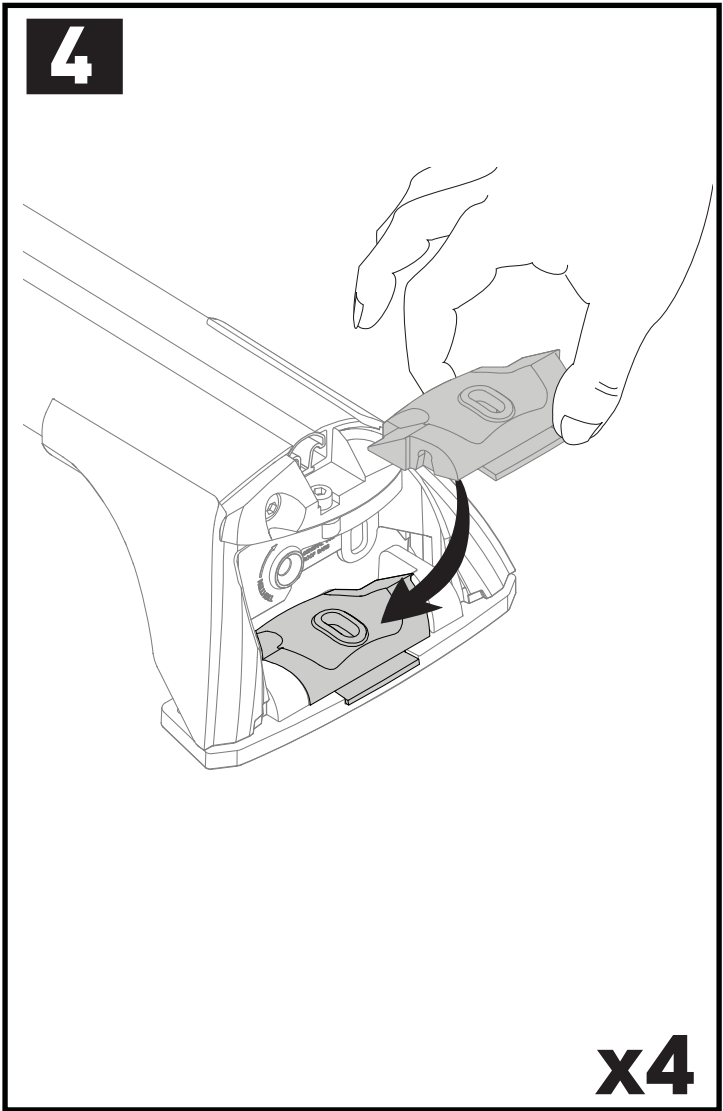
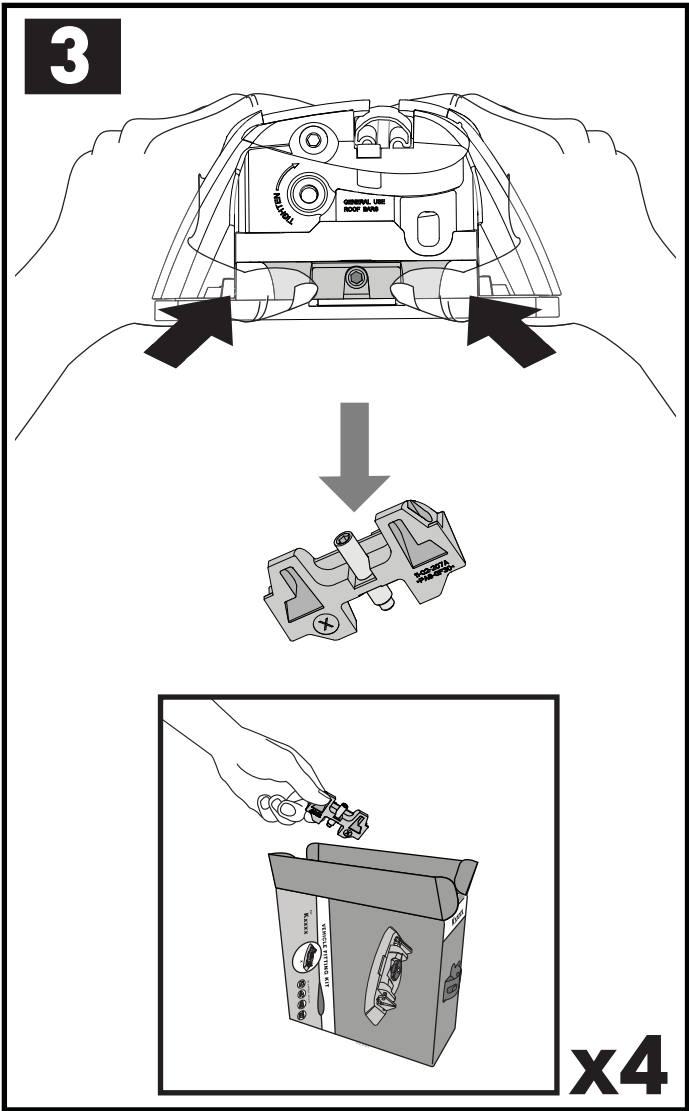

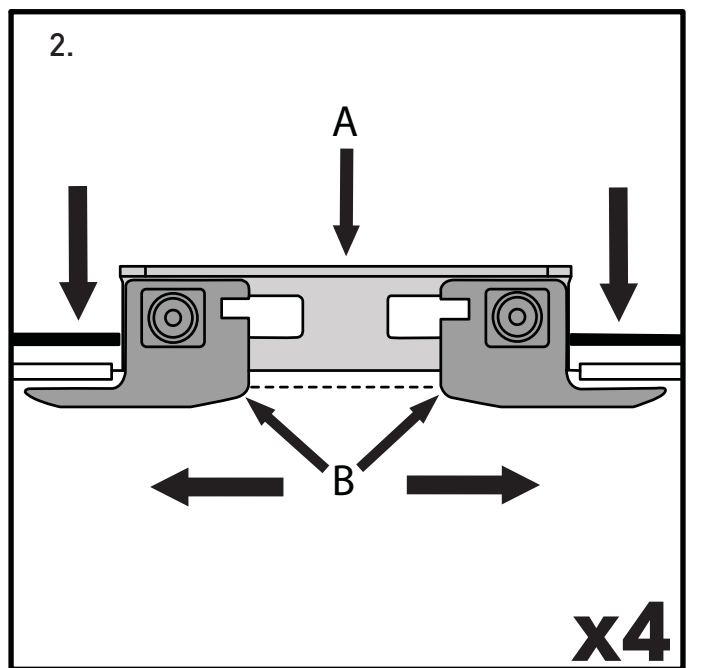
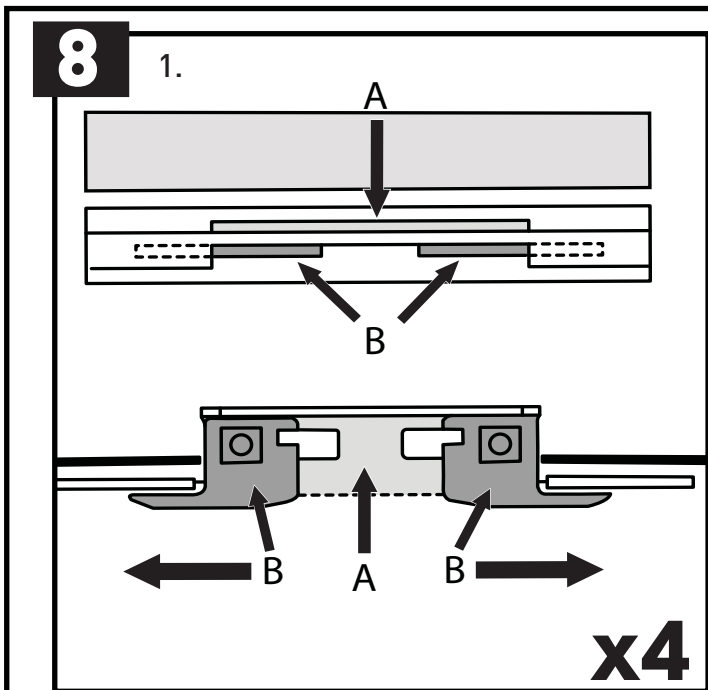
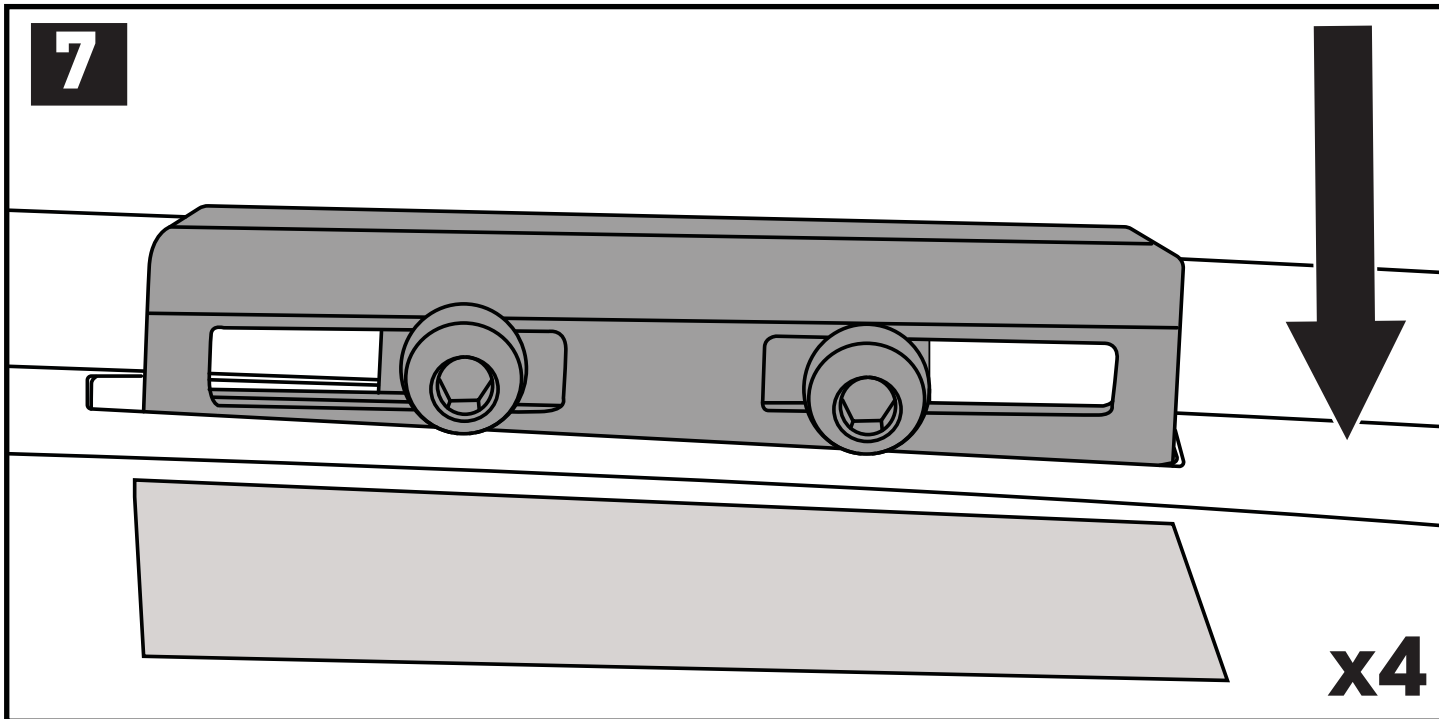
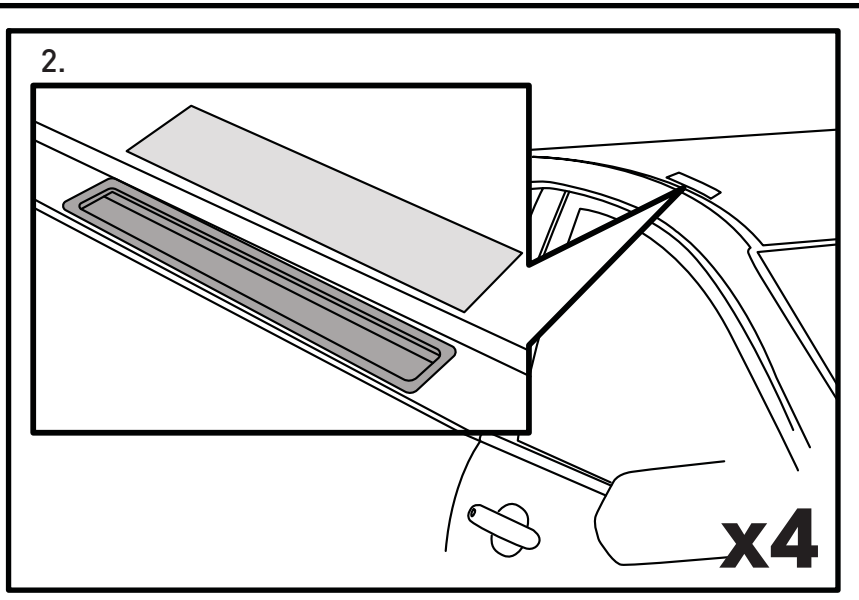
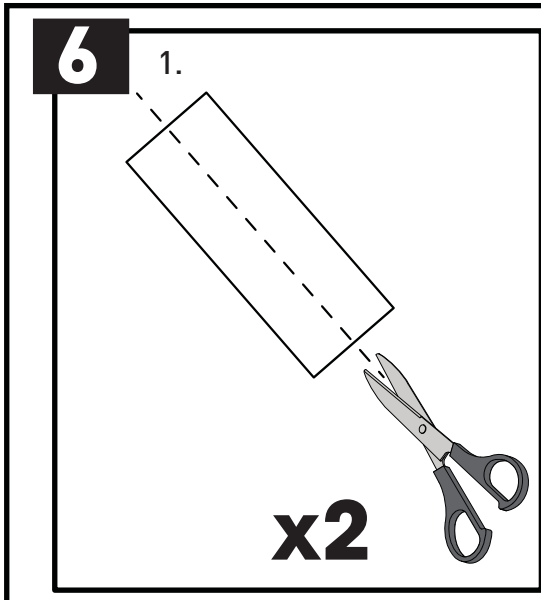

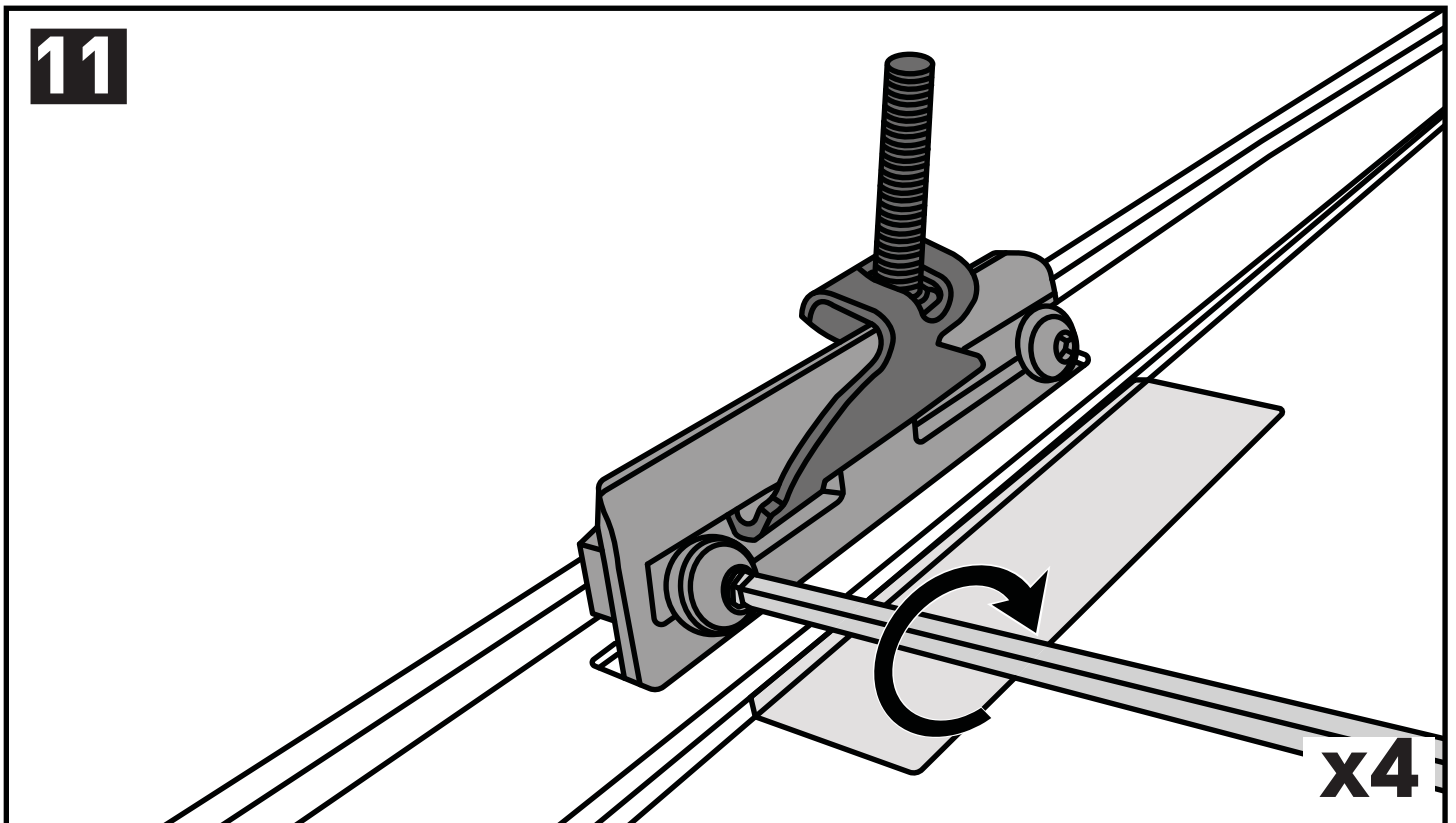
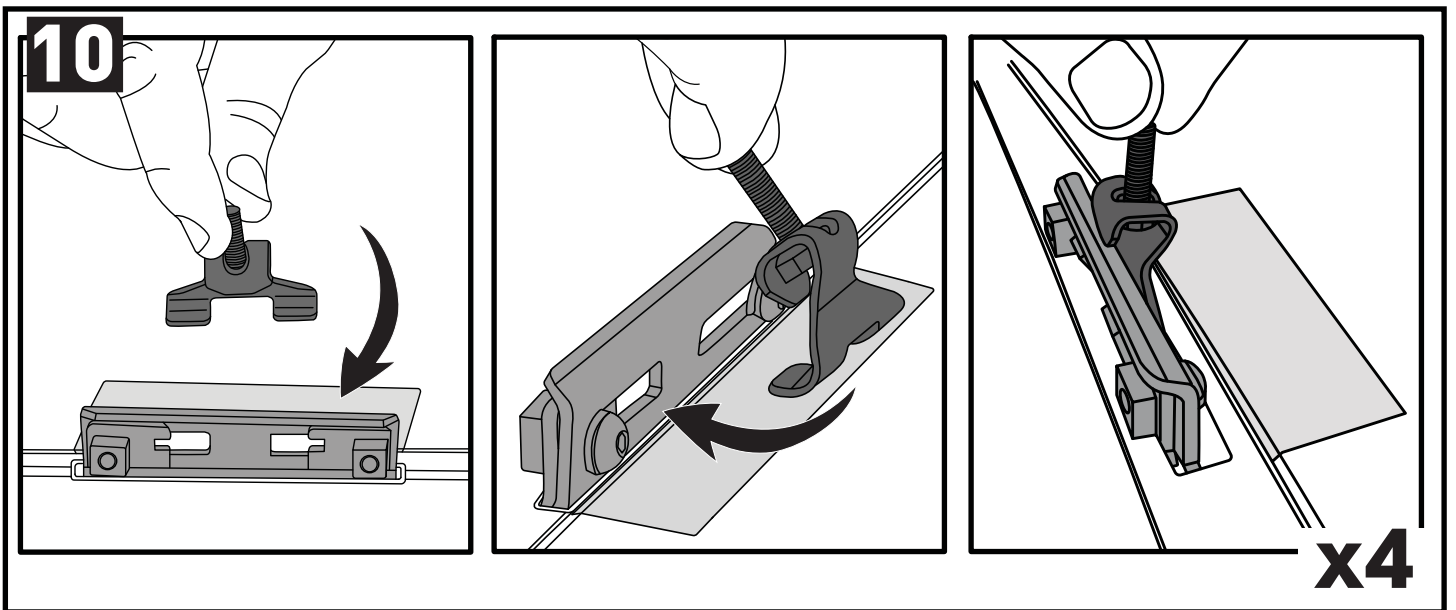
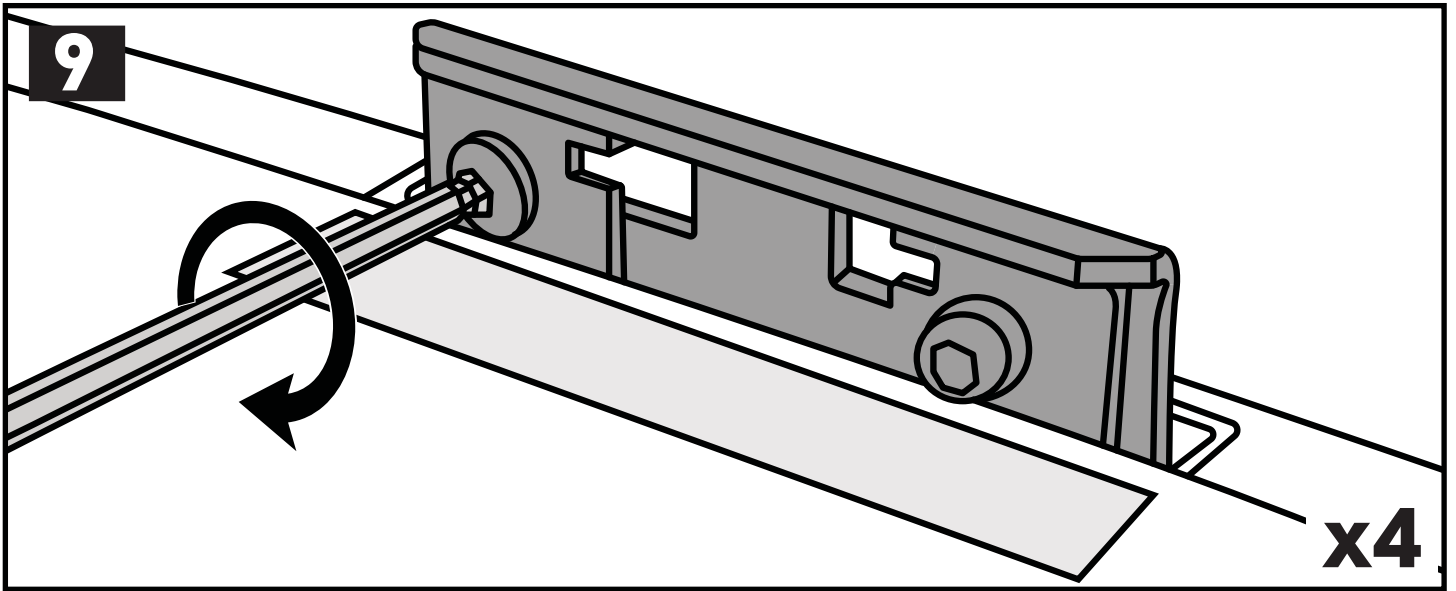

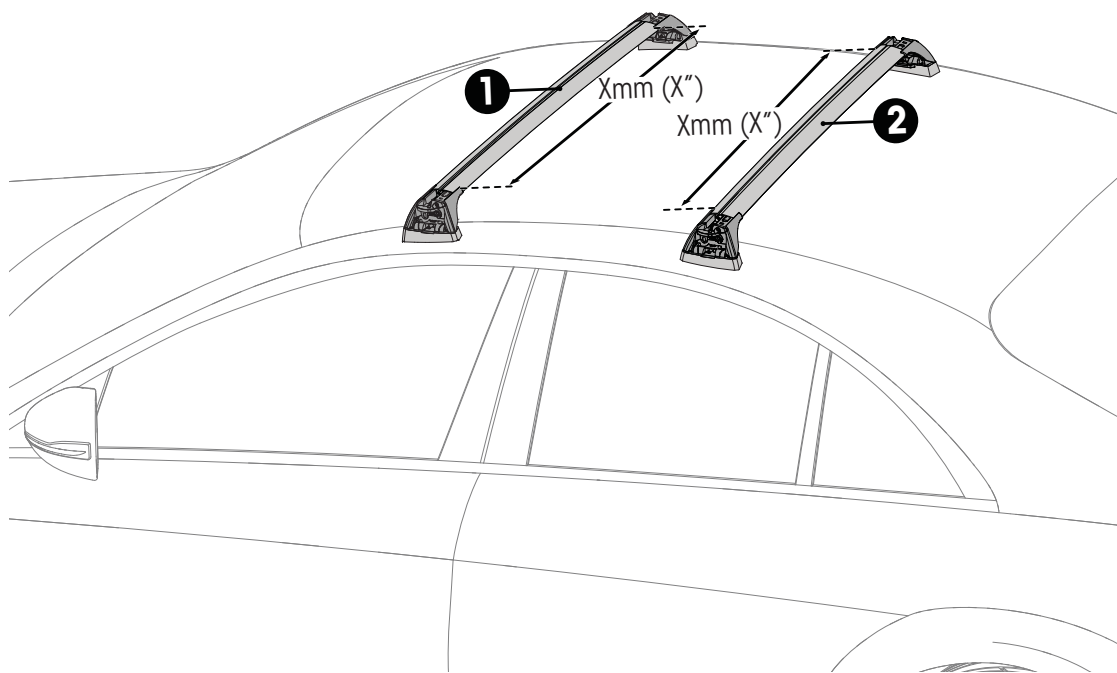
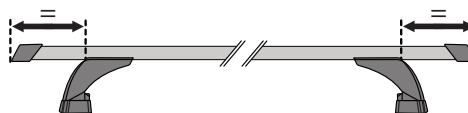
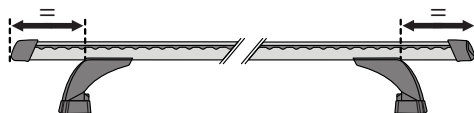
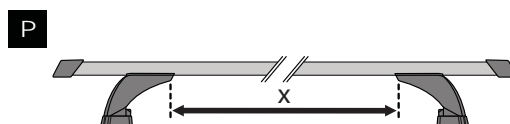
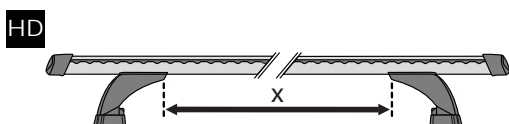
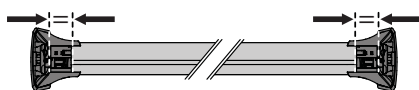
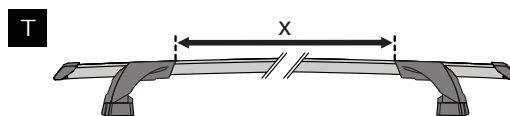
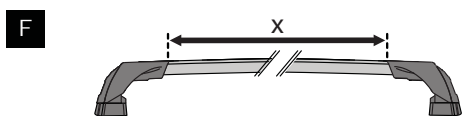
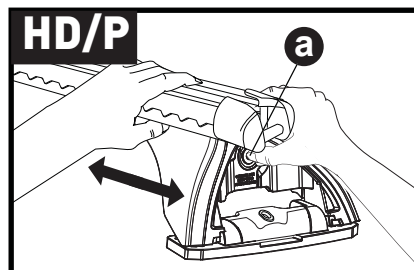
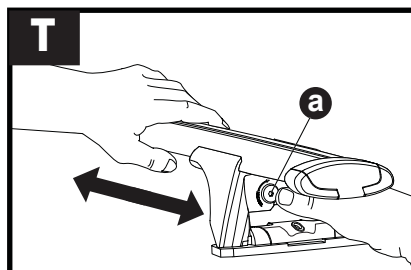
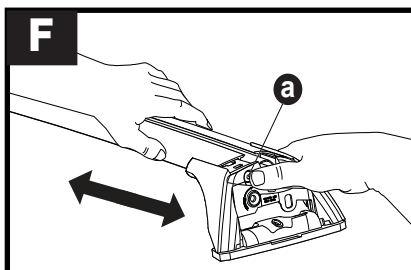

12



		1	2
Holden Commodore VE, 4dr Sedan Aug 06-May 13	AU	X = 875mm (34 1/2")	X = 845mm (33 1/4")
Holden Commodore VE, 4dr Sedan Sep 06-May 13	NZ	X = 875mm (34 1/2")	X = 845mm (33 1/4")
Holden Commodore VE, 5dr Wagon Apr 08-May 13	AU	X = 875mm (34 1/2")	X = 825mm (32 1/2")
Holden Commodore VE, 5dr Wagon Jul 08-May 13	NZ	X = 875mm (34 1/2")	X = 825mm (32 1/2")
Holden Commodore VF, 4dr Sedan Jun 13 -Mar 17	AU, NZ	X = 875mm (34 1/2")	X = 845mm (33 1/4")
Holden Commodore VF II, 5dr Sedan Apr 17-Feb 18	AU	X = 875mm (34 1/2")	X = 845mm (33 1/4")
Holden Commodore VF II, 5dr Sedan Apr 17-18	NZ	X = 875mm (34 1/2")	X = 845mm (33 1/4")
Holden Commodore VF, 5dr Wagon Jun 13 -Mar 17	AU, NZ	X = 875mm (34 1/2")	X = 825mm (32 1/2")
Holden Commodore VF II, 5dr Wagon Apr 17-Feb 18	AU	X = 875mm (34 1/2")	X = 825mm (32 1/2")
Holden Commodore VF II, 5dr Wagon Apr 17-18	NZ	X = 875mm (34 1/2")	X = 845mm (33 1/4")

13

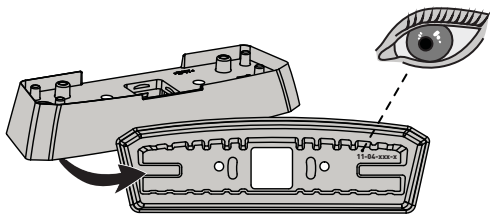

FR = 11-04-229-A

FL = 11-04-230-A

RR = 11-04-230-A

RL = 11-04-229-A

**PLACEMENT • PLATZIERUNG • COLOCACIÓN • MONTAGE • PLASSERING • COLOCAÇÃO • РАЗМЕЩЕНИЕ
MONTAGGIO • UMIESZCZENIE • UMÍSTĚNÍ • UMIESTNENIE • PLAATSING • PLACERING**

14

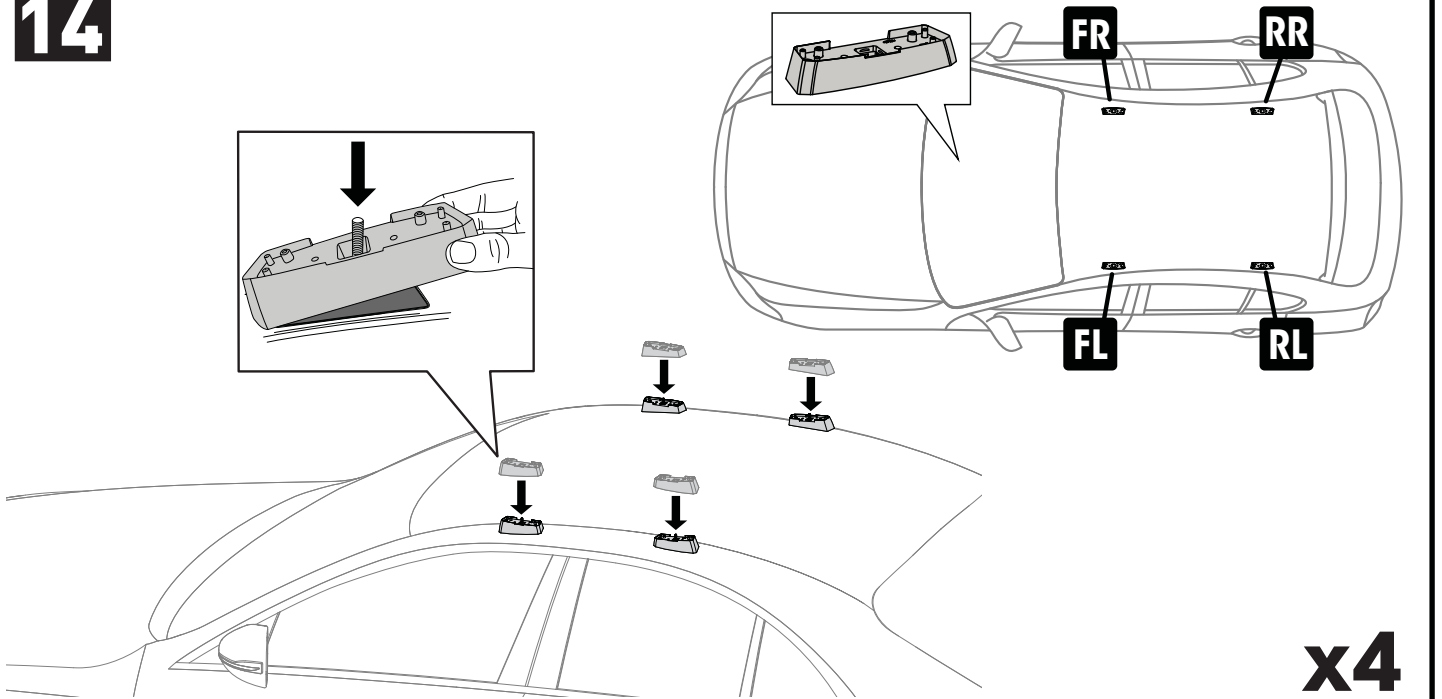

15

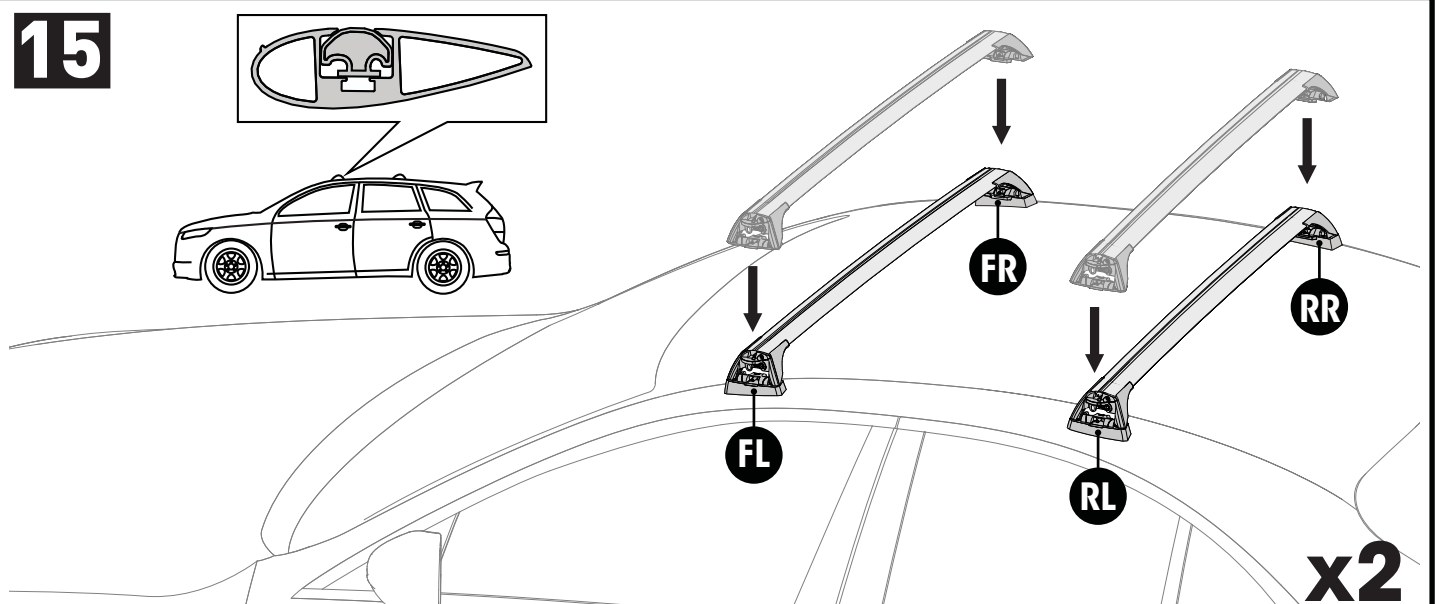

16

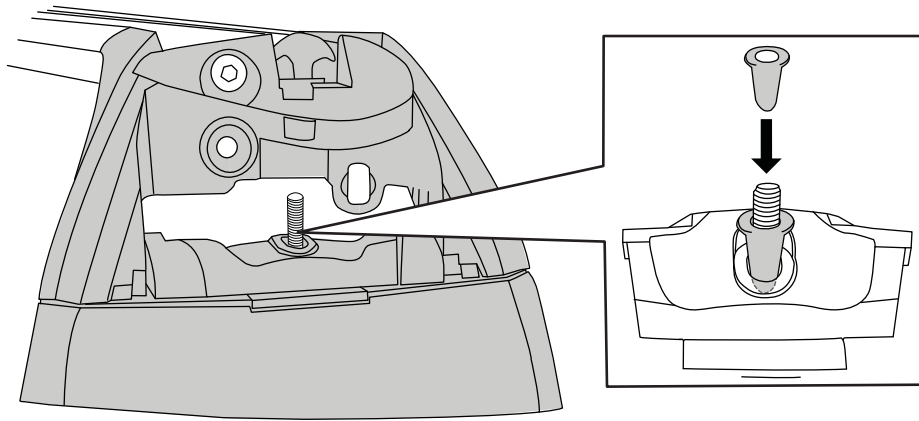

x4

17

**2Nm
(18 lb-in)**

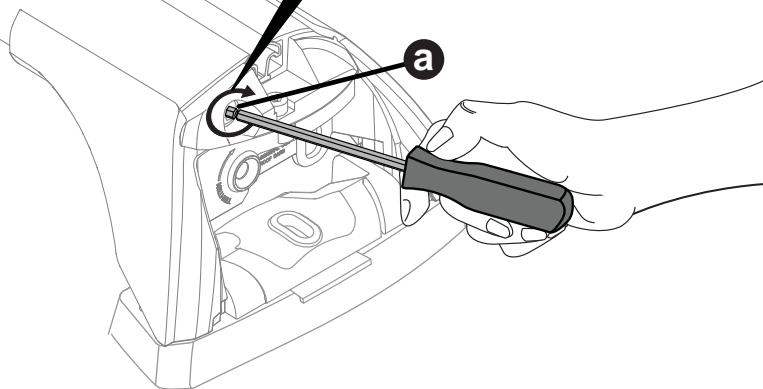

x4

18

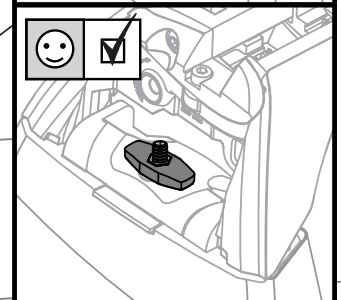
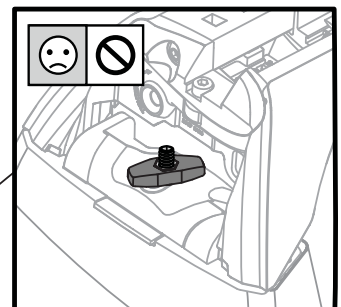
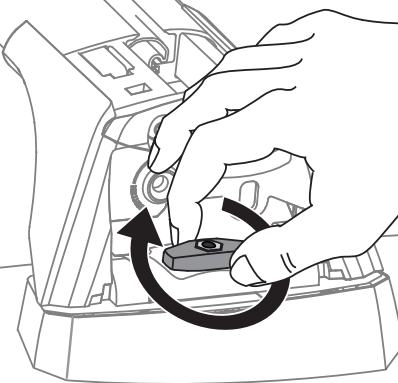
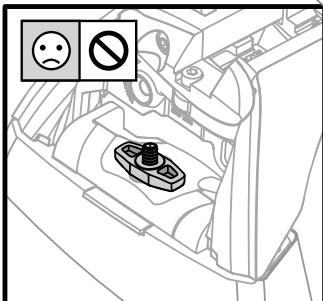

x4

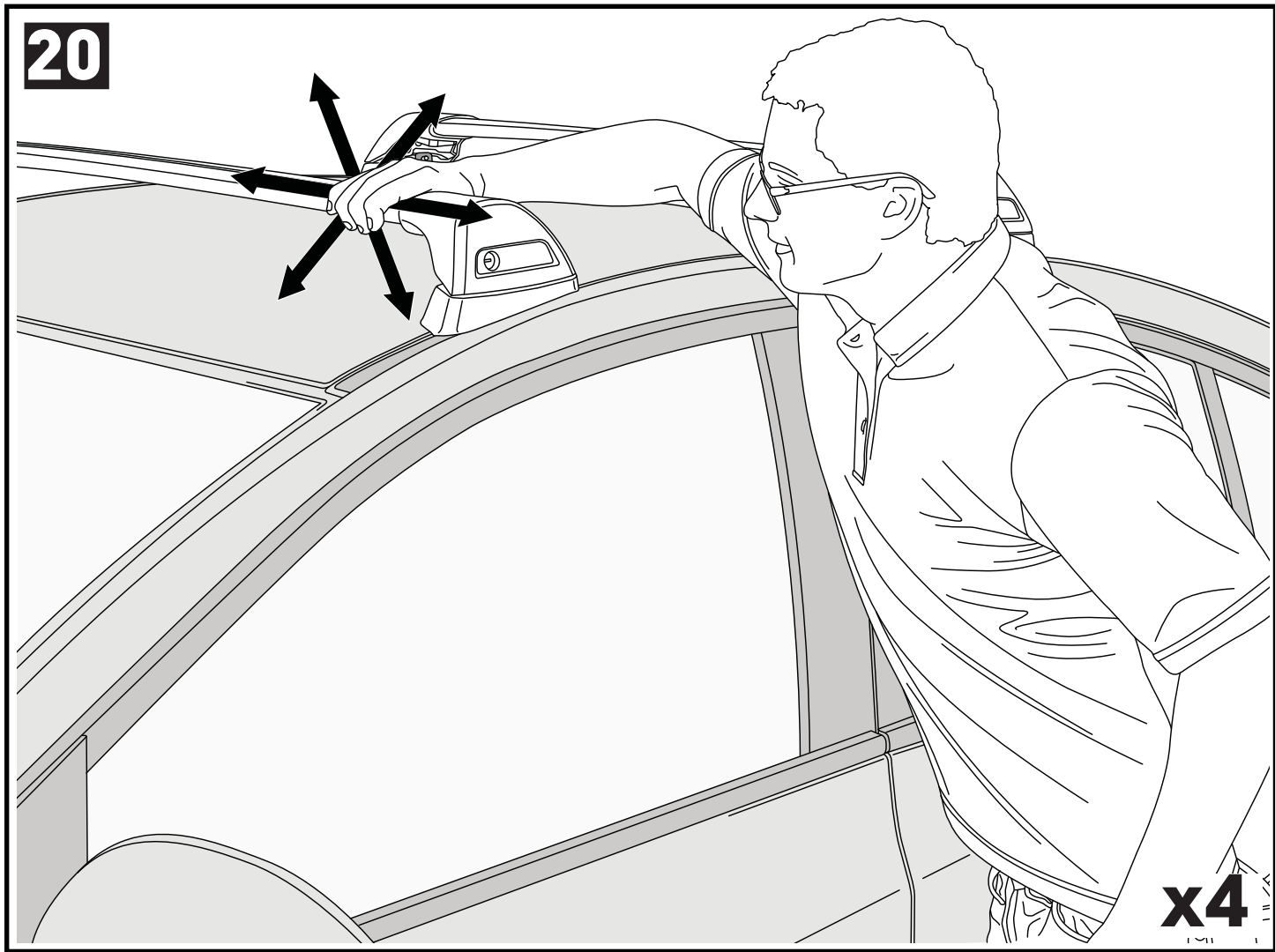
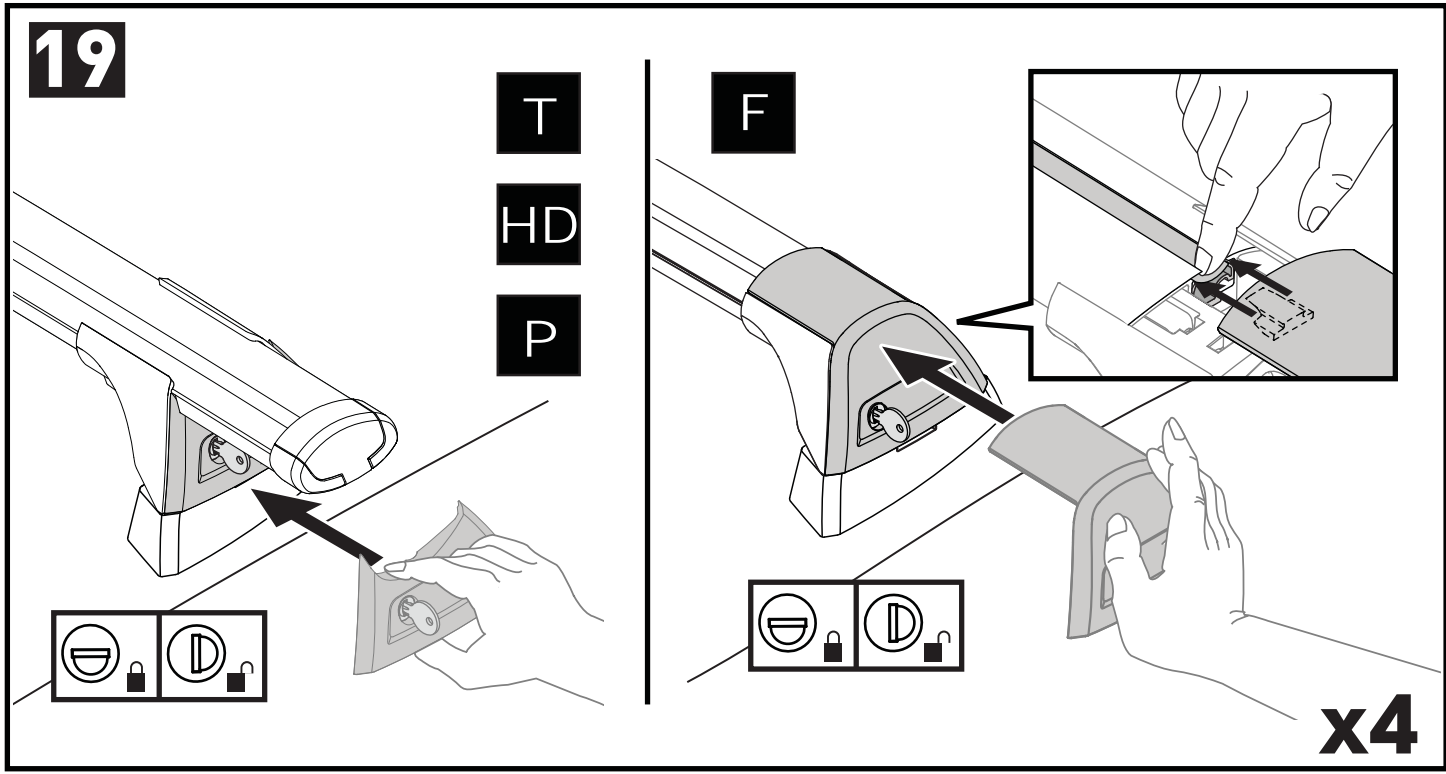

**ATTENTION • ACHTUNG • ATENCIÓN • ATTENTION • OPPMERKSOMHET • ATENÇÃO • ВНИМАНИЕ
ATTENZIONE • UWAGA • UPOZORNĚNÍ • UPOZORNENIE • LET OP • UPPMÄRSAMHET**

- EN** Please read safety and warranty booklet included with this product prior to use. For more information visit your local dealer.
- DE** Bitte lesen und beachten Sie die beiliegende Montageanleitung, Sicherheitshinweise und Garantiebedingungen bevor Sie das Produkt montieren/benutzen. Für weitere Informationen kontaktieren Sie bitte Ihren Händler.
- ES** Por favor, lea folleto de seguridad y garantía que se incluye con este producto antes de su uso. Para obtener más información, visite a su distribuidor local.
- FR** Veuillez lire attentivement le manuel de sécurité et de garantie avant utilisation. Pour plus d'informations, visitez votre concessionnaire local.
- NO** Vennligst les hefte om sikkerhet og garanti som er vedlagt dette produkt før det tas i bruk. For mer informasjon ta kontakt med din forhandler.
- PT** Por favor leia o manual de segurança e garantia incluído, antes de utilizar o produto. Para mais informações visite o seu revendedor local.
- RU** Пожалуйста, ознакомьтесь с инструкцией перед тем, как использовать товар. Для получения более подробной информации обратитесь к местному дилеру.
- IT** Si prega di leggere il libretto di sicurezza e garanzia incluso nel prodotto prima dell'uso. Per maggiori informazioni visita il rivenditore locale.
- PL** Proszę zapoznać się z warunkami gwarancji i bezpieczeństwa przed użyciem produktu. W celu uzyskania dodatkowych informacji proszę kontaktować się z najbliższym autoryzowanym punktem sprzedaży.
- CS** Před použitím si prosím přečtete přiložené informace o bezpečnosti a záručních podmínkách. Pro více informací navštivte nejbližšího dealera.
- SK** Pred použitím si prosím prečítajte priložené informácie o bezpečnosti a záručných podmienkach. Pre viac informácií navštívte najbližšieho diera.
- NL** A.U.B. bijgesloten garantie- en veiligheidsinstructies grondig lezen voor gebruik van dit product. Voor meer informatie graag contact opnemen met uw dealer.
- SV** Var snäll och läs igenom säkerhets- och garantihäftet som medföljer produkten före användning. För mer information besök din lokala återförsäljare.

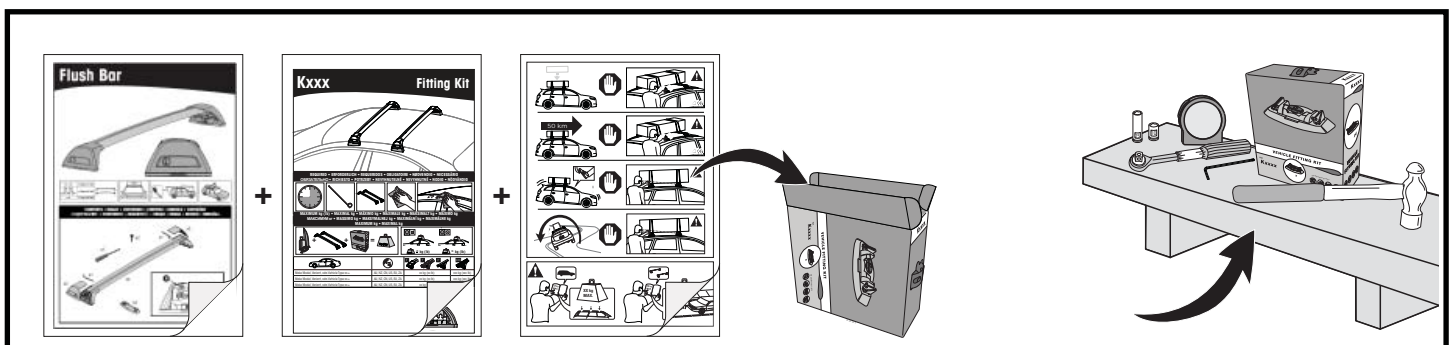
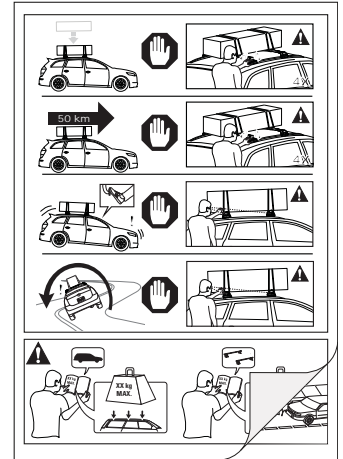

Yakima Australia Pty Ltd
17 Hinkler Court, Brendale
QLD 4500, Australia
1800 143 548
www.prorack.com.au
www.whispbar.com.au

Yakima Europe Coöperatief U.A.
Twentehaven 7, 3433
PT Nieuwegein, The Netherlands
+31 2080 81425
www.prorackeurope.eu
www.whispbar.eu

Yakima Products, Inc.
4101 Kruse Way
Lake Oswego, OR. 97035 USA
888 925 4621
www.whispbar.com