

K677

Fitting Kit

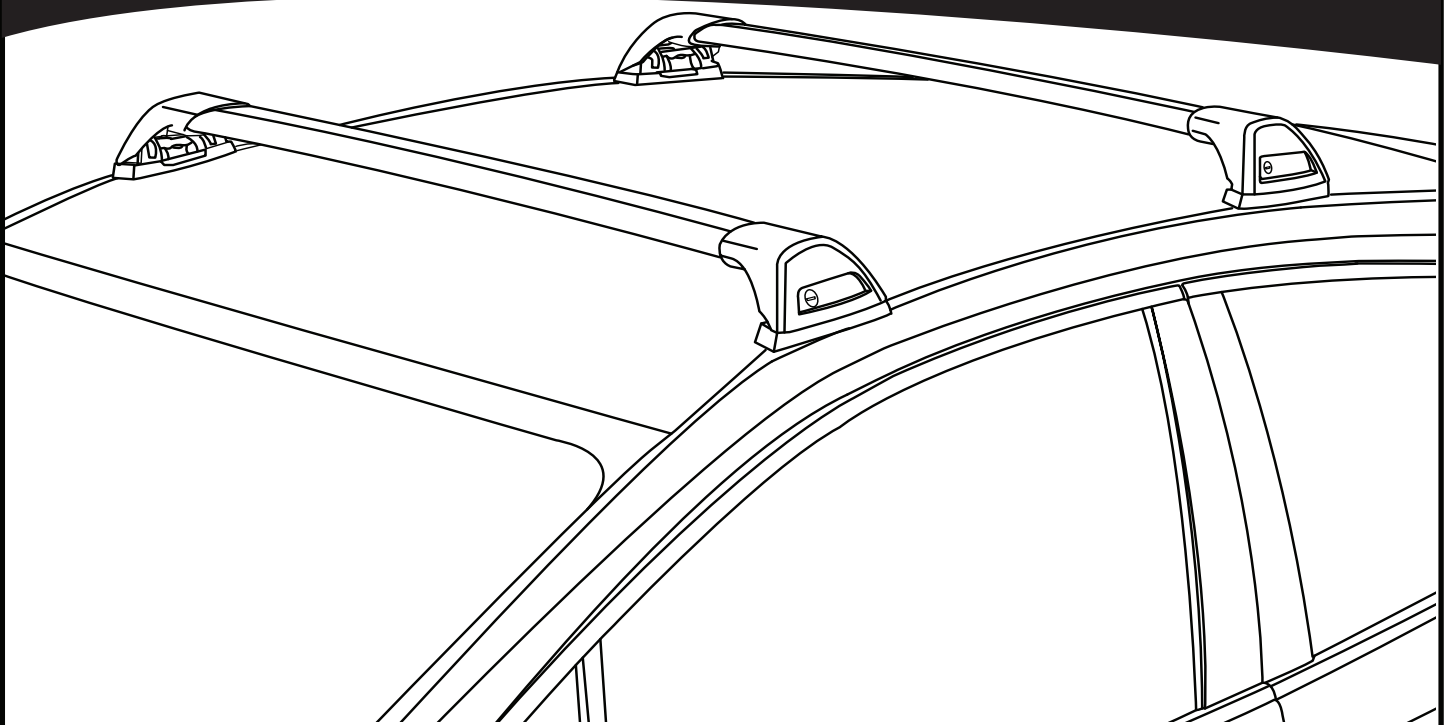

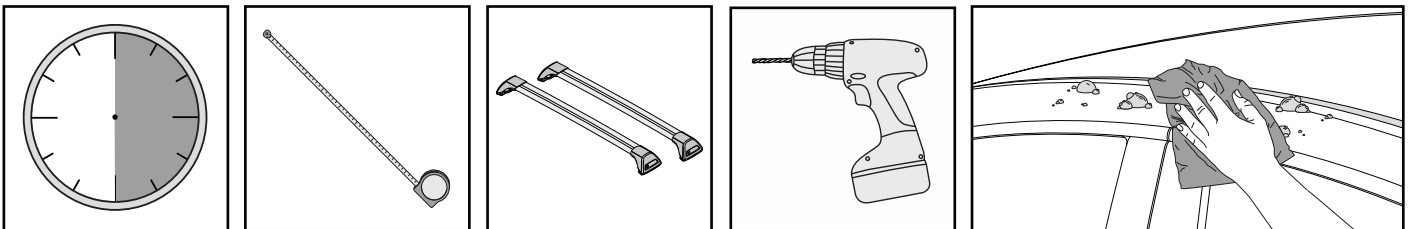



REQUIRED • ERFORDERLICH • REQUERIDOS • OBLIGATOIRE • NØDVENDIG • NECESSÁRIO • ОБЯЗАТЕЛЬНО • OBLIGATORIO
 POTRZEBY • NEVYHNUTELNÉ • NEVYHNUTNÉ • NODIG • NÖDVÄNDIG • PÅKRÆVET • ПОТРІБНА • EDELLYTETÄÄN

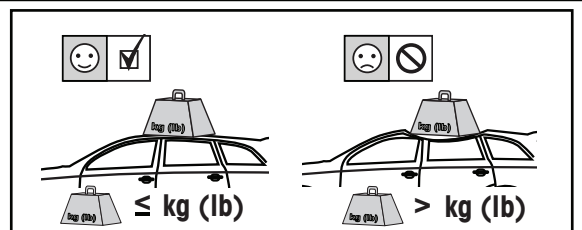
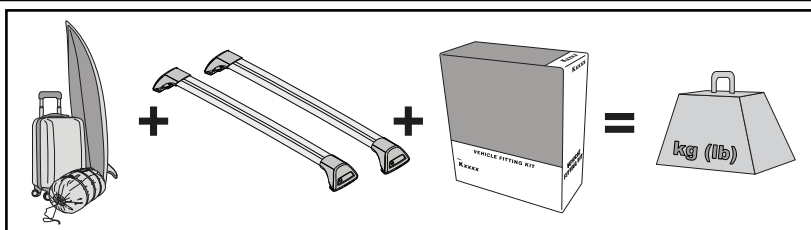

MAXIMUM kg (lb) • MAXIMUM kg • MÁXIMO kg • MAXIMUM kg • MAKSIMALT kg • MÁXIMO kg
 МАКСИМУМ кг • MASSIMO kg • MAKSIMALNEJ kg • MAXIMÁLNÍ kg • MAXIMÁLNE kg
 MAXIMUM kg • MAXIMAL kg • MAKSIMAL kg • МАКСИМАЛЬНА kg • ENIMMÄISMÄÄRÄ kg

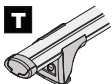

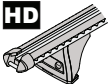
		F 	T 	P 	HD 
Mitsubishi Outlander Aspire, 5dr SUV 12+	AU	75 kg (165 lb)			75 kg (165 lb)
Mitsubishi Outlander ES, 5dr SUV 12+	AU	75 kg (165 lb)			75 kg (165 lb)
Mitsubishi Outlander GX1, 5dr SUV 12+	EU	75 kg (165 lb)			75 kg (165 lb)
Mitsubishi Outlander GX2, 5dr SUV 12+	EU	75 kg (165 lb)			75 kg (165 lb)
Mitsubishi Outlander LS 2WD, 5dr SUV 12+	NZ	75 kg (165 lb)			75 kg (165 lb)
Mitsubishi Outlander LS, 5dr SUV 12+	AU	75 kg (165 lb)			75 kg (165 lb)

**CONTENTS • INHALT • CONTENIDO • CONTENU • INNHOLD • CONTEÚDO • СОДЕРЖАНИЕ • CONTENUTO
ZAWARTOŚĆ • OBSAH • OBSAH • INHOUD • INNEHÅLL • INDHOLD • ЗМІСТ • SISÄLLYS**

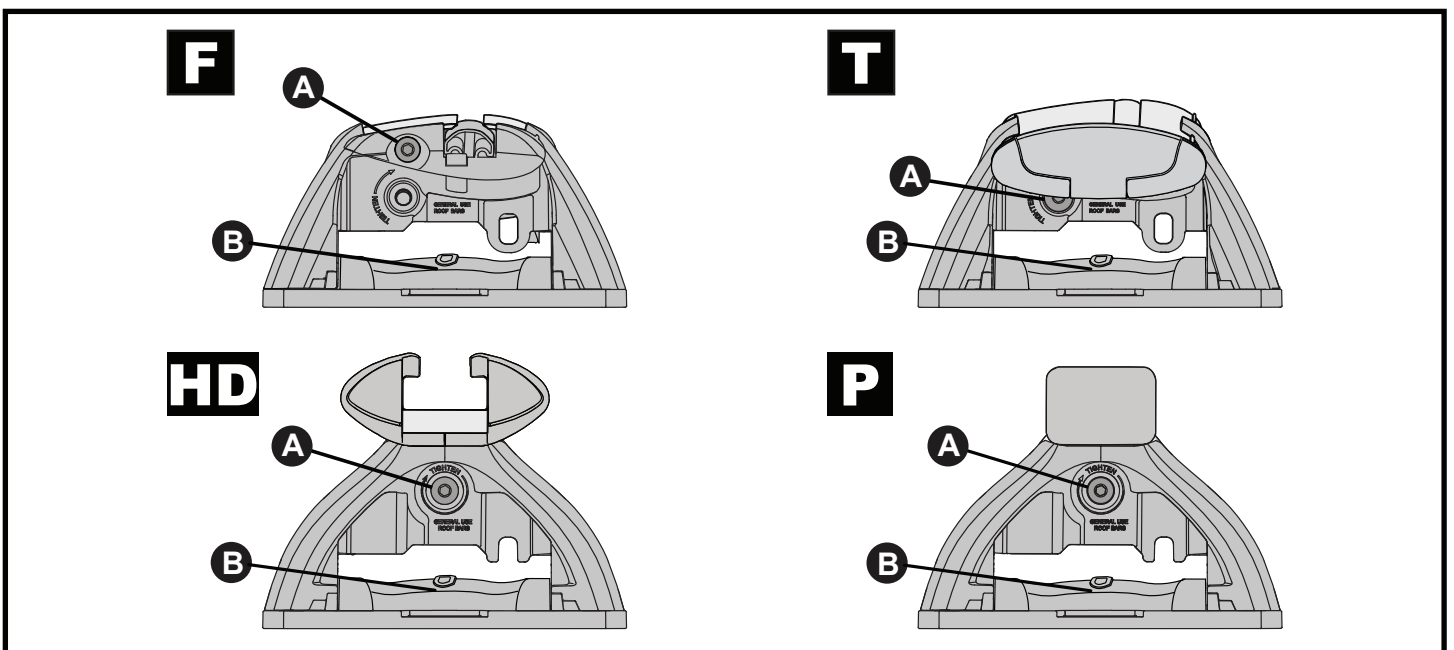
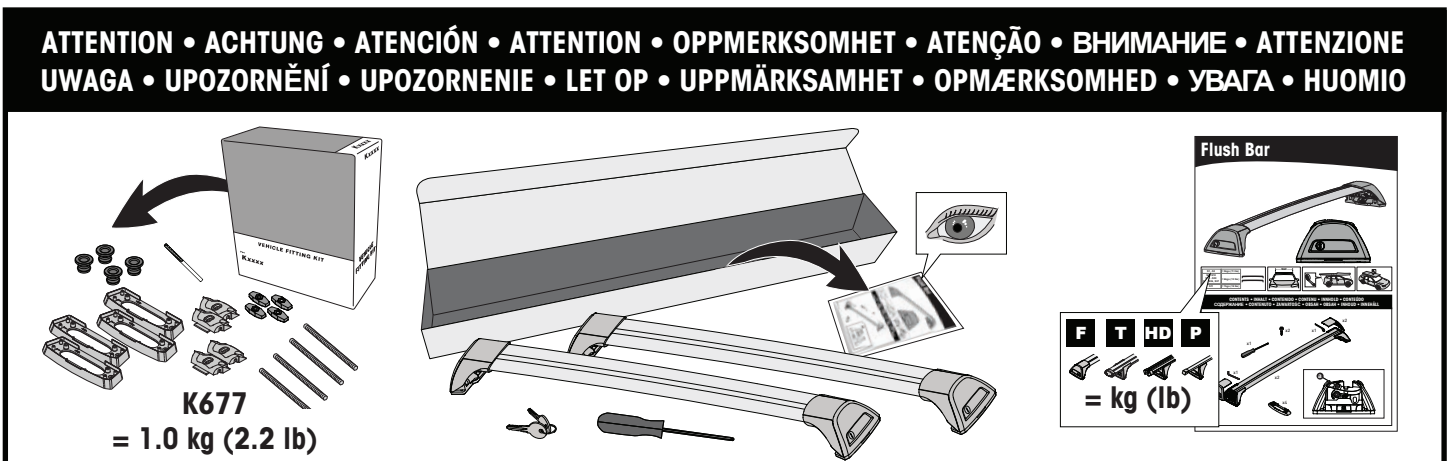
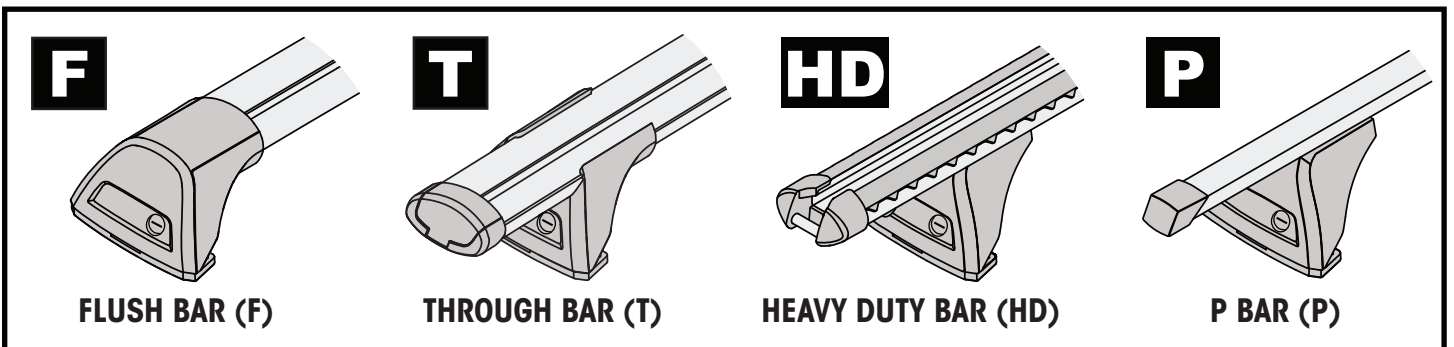
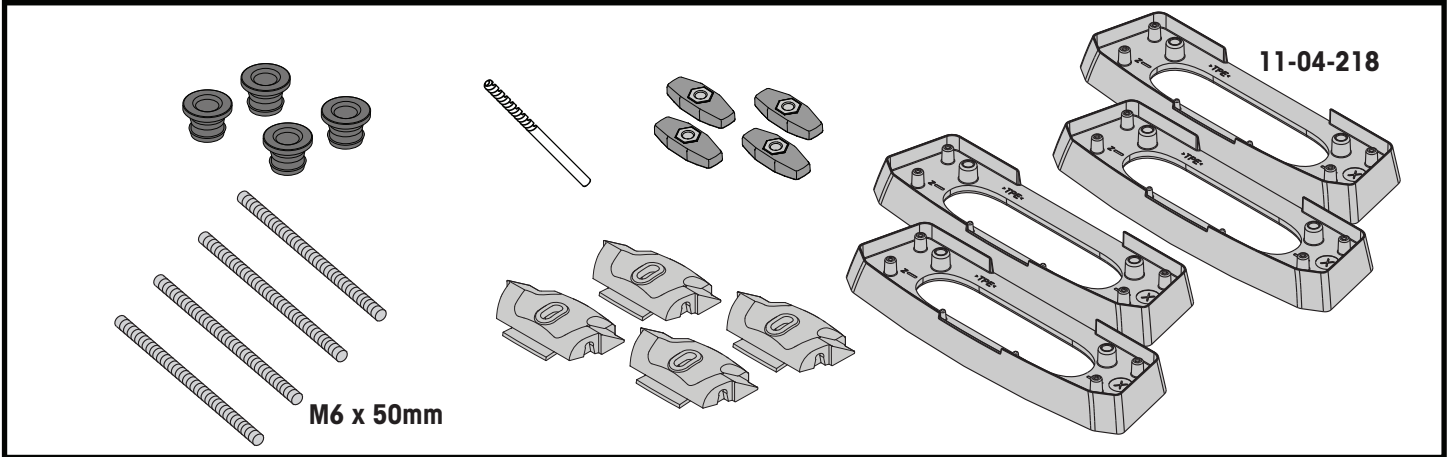

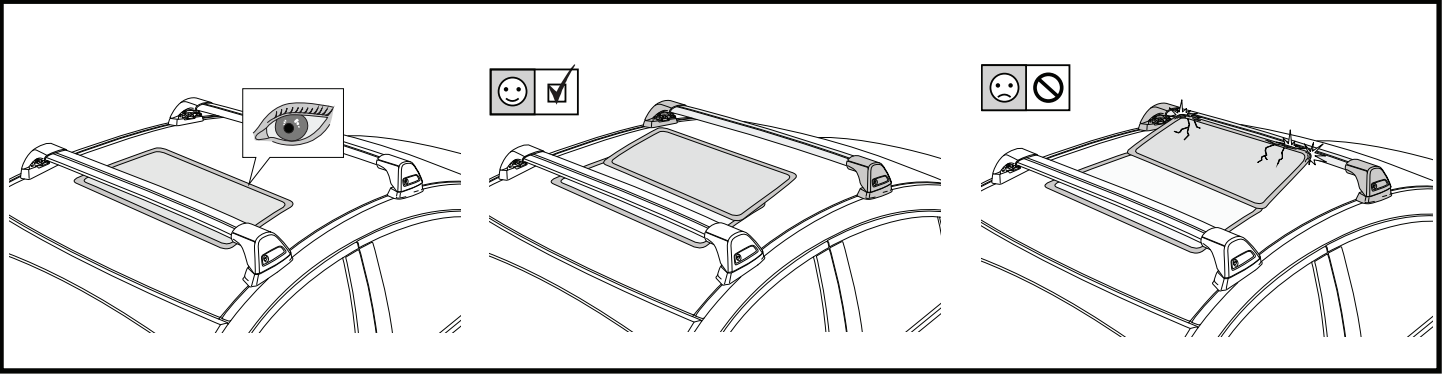

1

F

T
HD
P

x4

2

HD/P

F/T

x10
a

x4

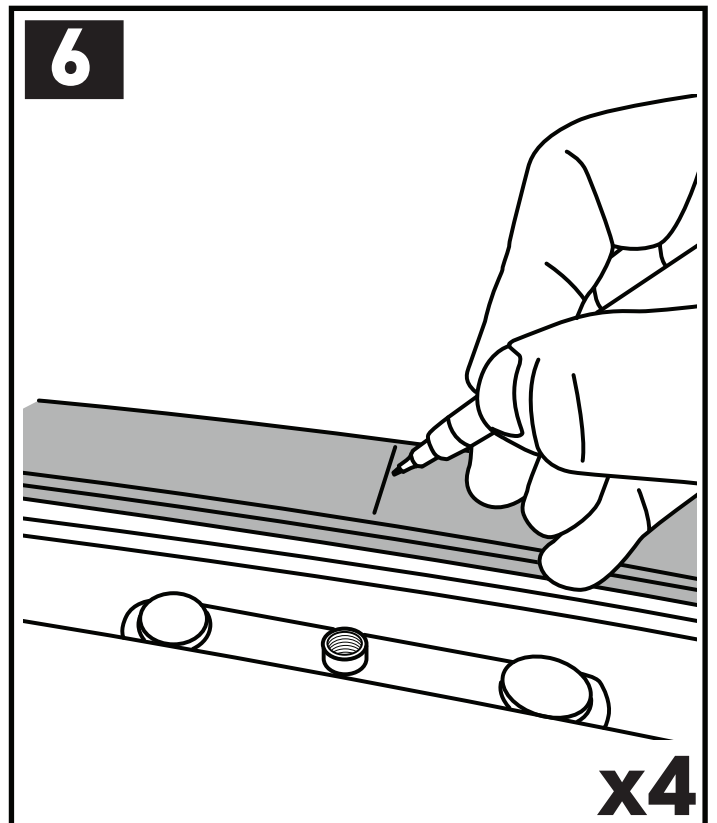
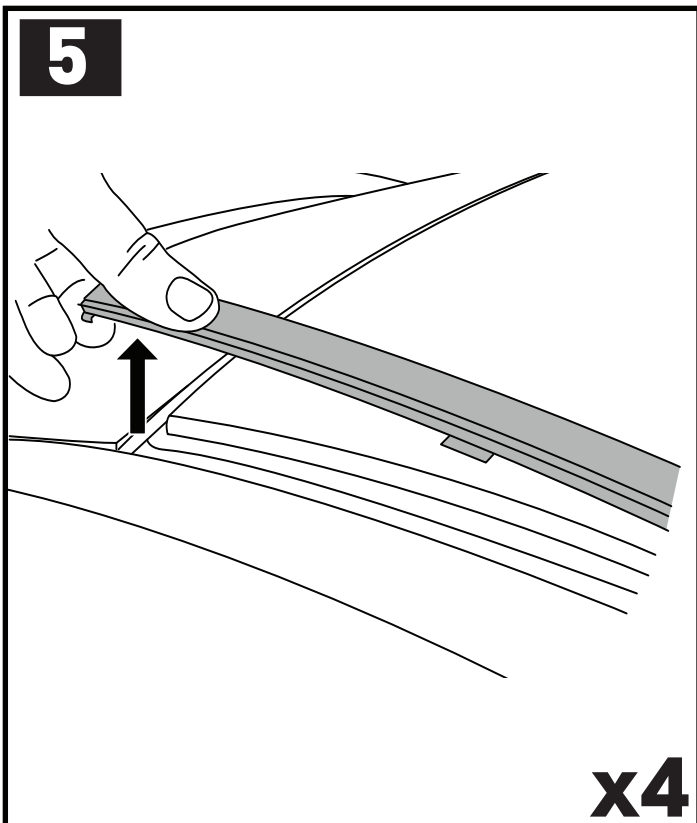
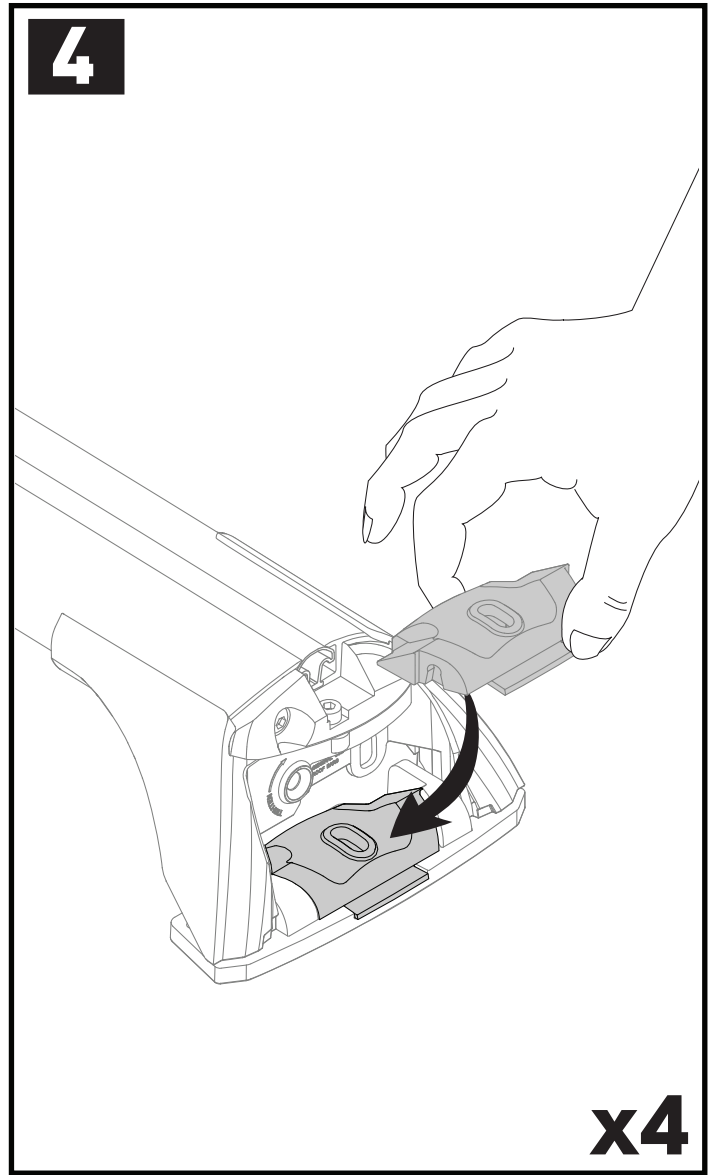
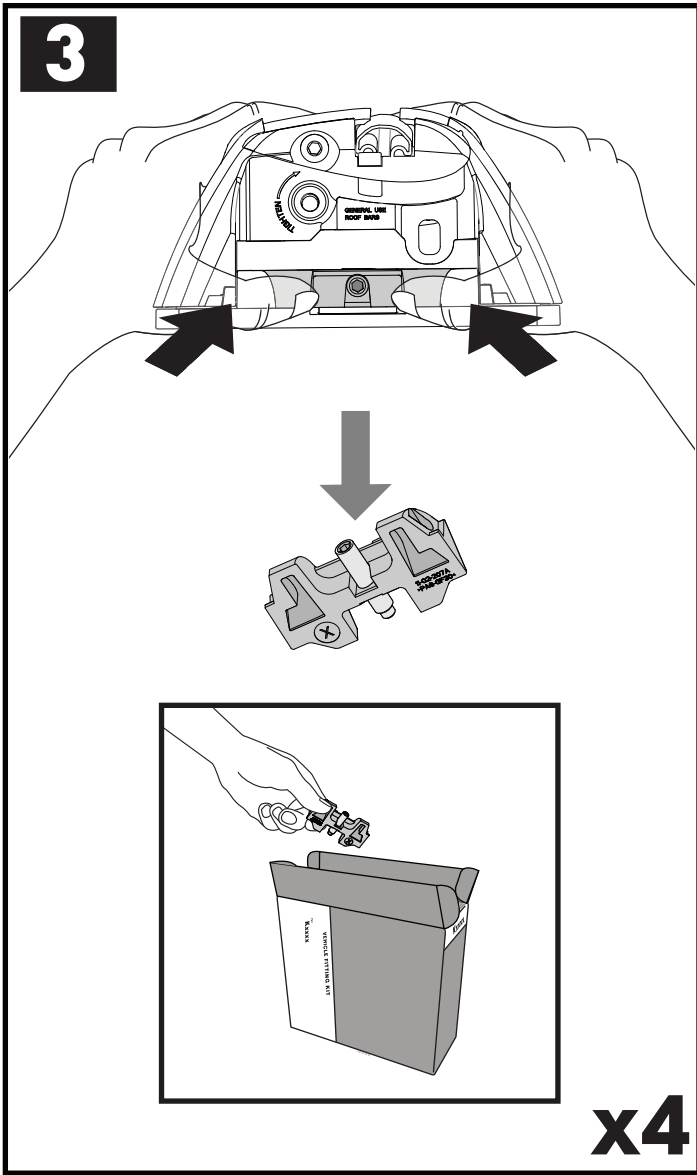

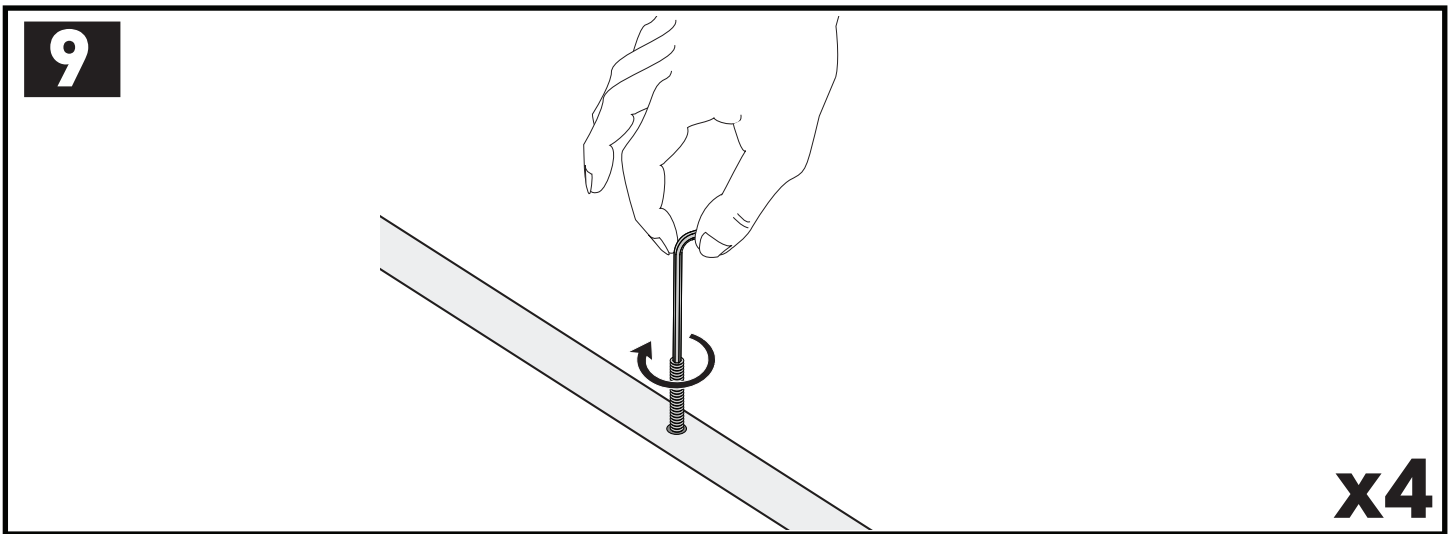
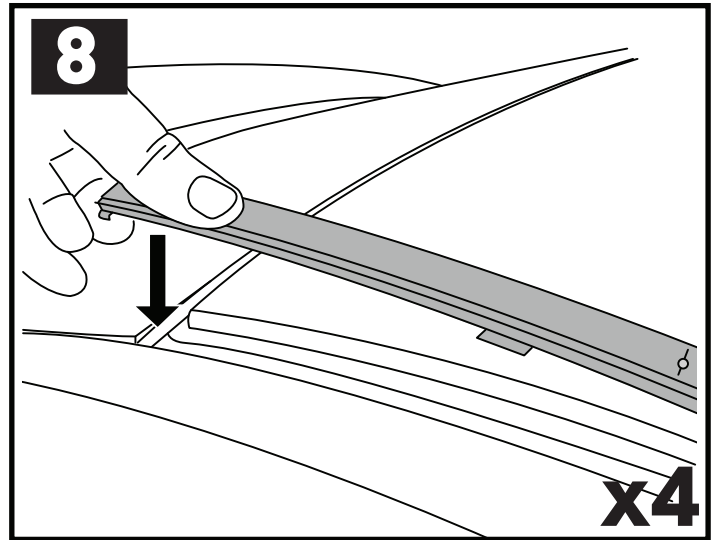
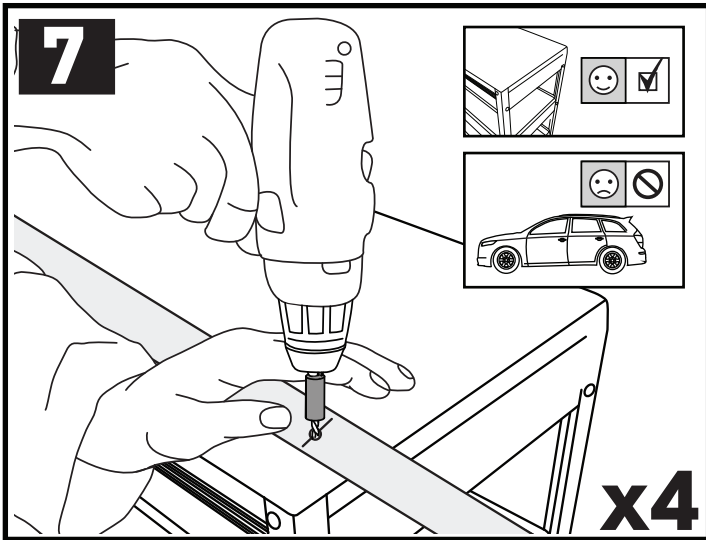

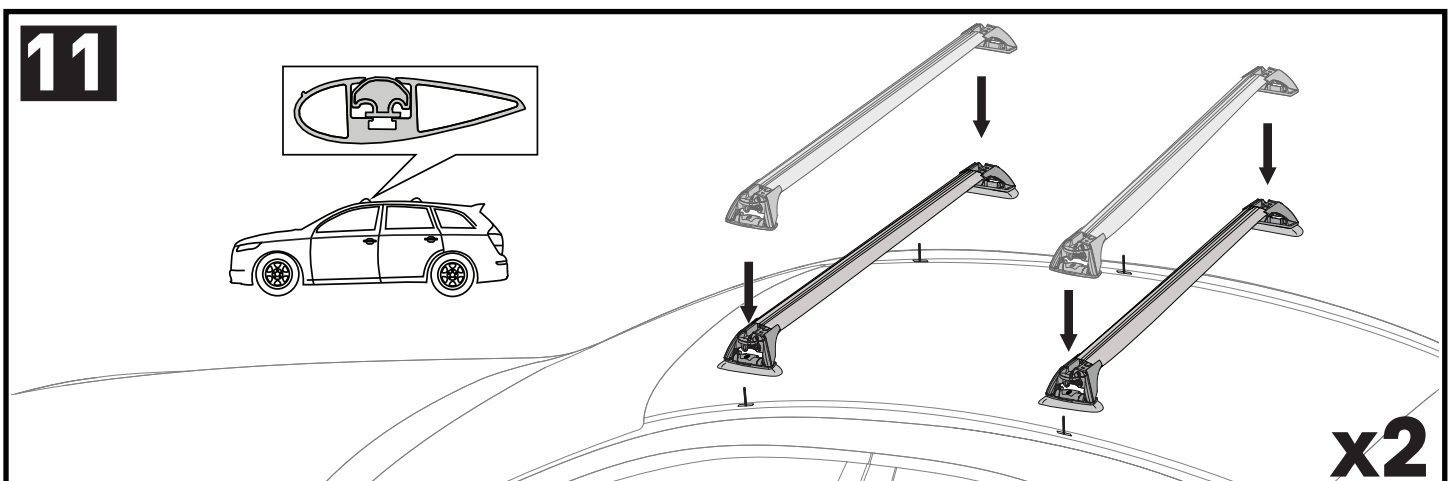
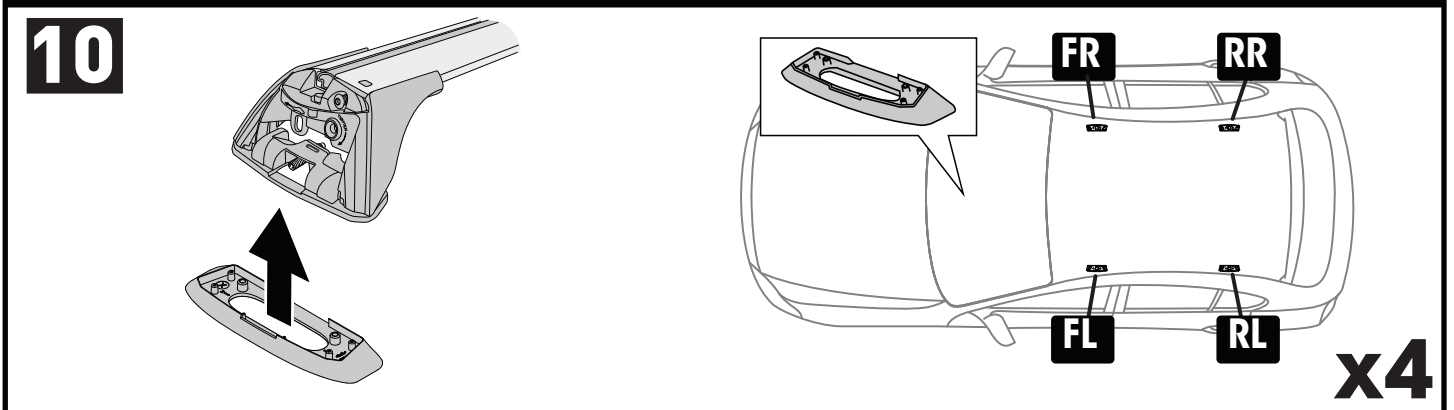

PLACEMENT • PLATZIERUNG • COLOCACIÓN • MONTAGE • PLASSERING • COLOCAÇÃO • РАЗМЕЩЕНИЕ • MONTAGGIO
 UMIESZCZENIE • UMÍSTĚNÍ • UMIESTNENIE • PLAATSING • PLACERING • PLACERING • РОЗМІЩЕННЯ • SIJOITTA

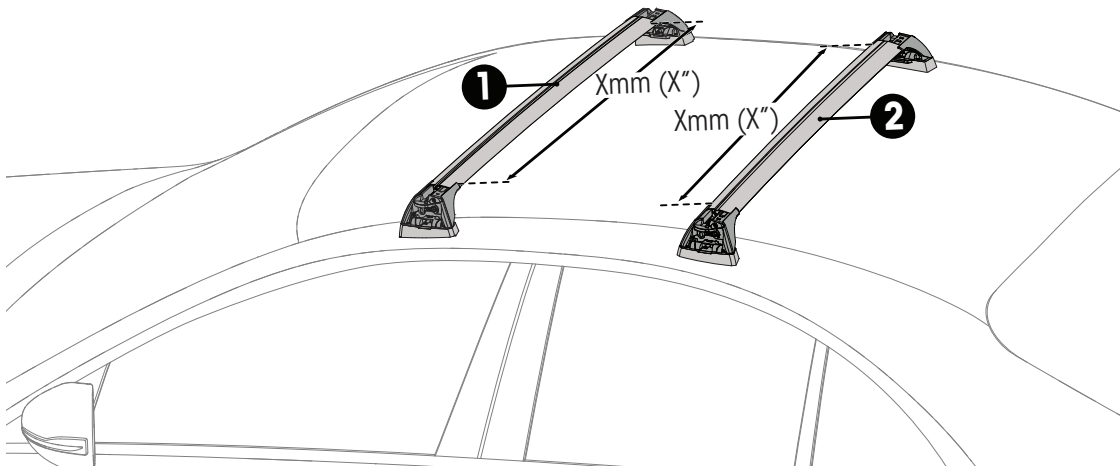
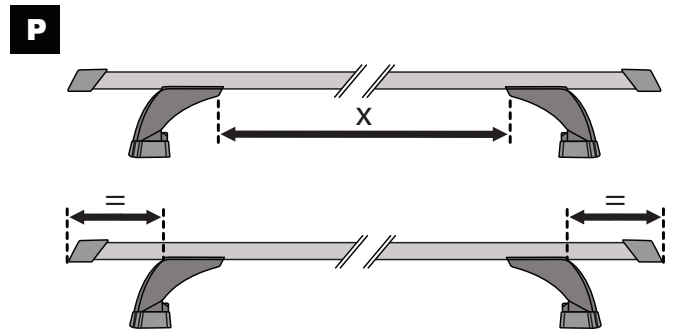
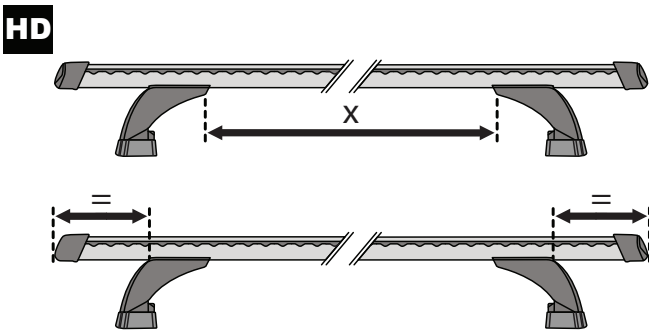
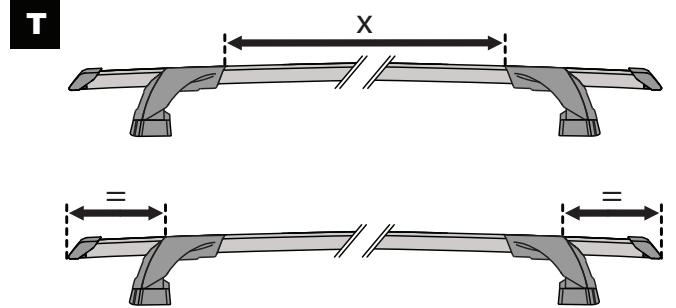
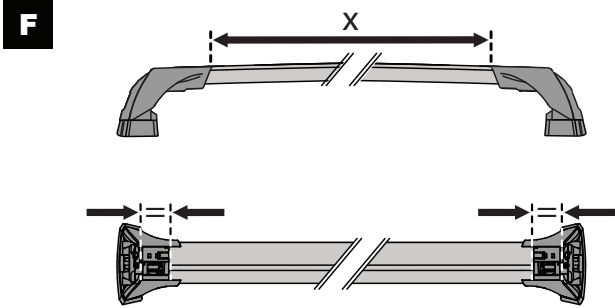
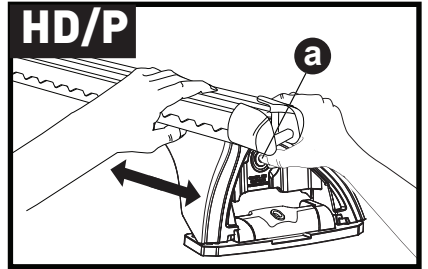
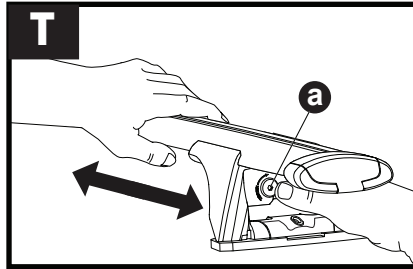
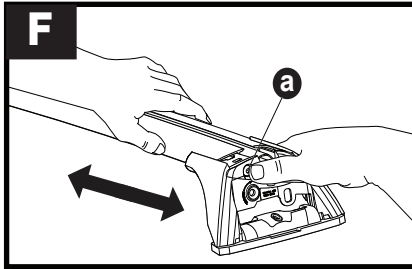

12



		1	2	A	B
Mitsubishi Outlander Aspire, 5dr SUV 12+	AU	X = 960 mm (37 3/4")	X = 910 mm (35 7/8")	-A = 300 mm (11 3/4")	B = 450 mm (17 3/4")
Mitsubishi Outlander ES, 5dr SUV 12+	AU	X = 960 mm (37 3/4")	X = 910 mm (35 7/8")	-A = 300 mm (11 3/4")	B = 450 mm (17 3/4")
Mitsubishi Outlander GX1, 5dr SUV 12+	EU	X = 960 mm (37 3/4")	X = 910 mm (35 7/8")	-A = 300 mm (11 3/4")	B = 450 mm (17 3/4")
Mitsubishi Outlander GX2, 5dr SUV 12+	EU	X = 960 mm (37 3/4")	X = 910 mm (35 7/8")	-A = 300 mm (11 3/4")	B = 450 mm (17 3/4")
Mitsubishi Outlander LS 2WD, 5dr SUV 12+	NZ	X = 960 mm (37 3/4")	X = 910 mm (35 7/8")	-A = 300 mm (11 3/4")	B = 450 mm (17 3/4")
Mitsubishi Outlander LS, 5dr SUV 12+	AU	X = 960 mm (37 3/4")	X = 910 mm (35 7/8")	-A = 300 mm (11 3/4")	B = 450 mm (17 3/4")

13

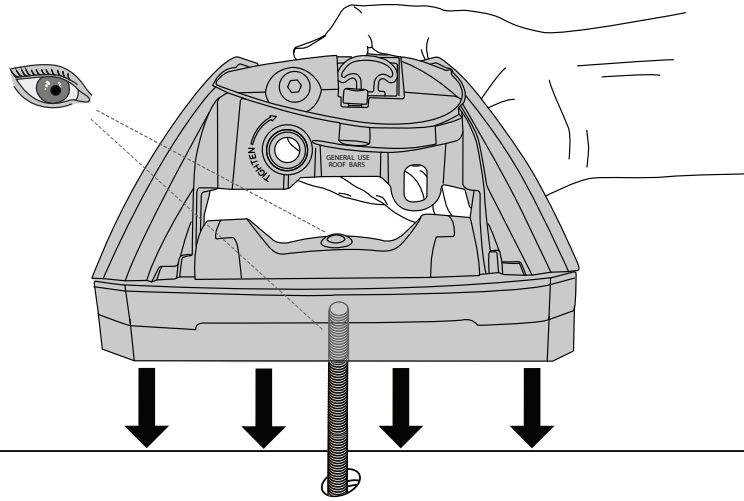

x4

14

**2Nm
(18 lb-in)**

a

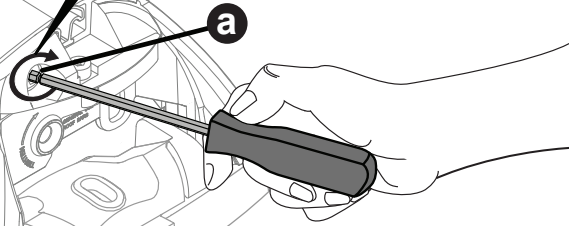

x4

15

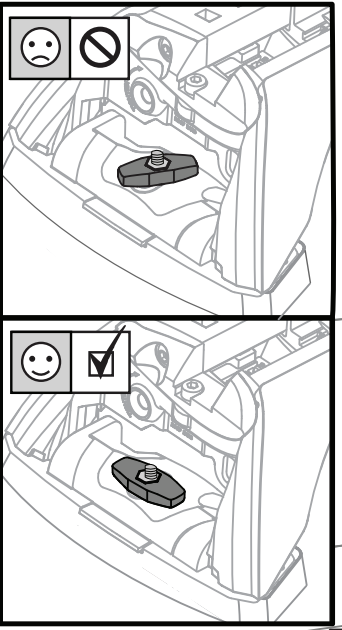
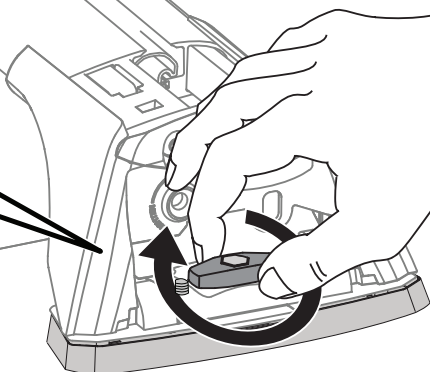
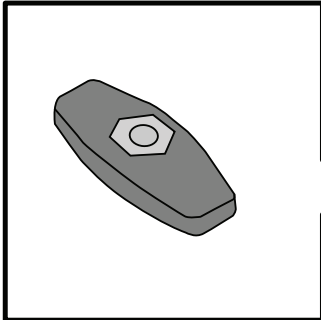

x4

16

T
HD
P

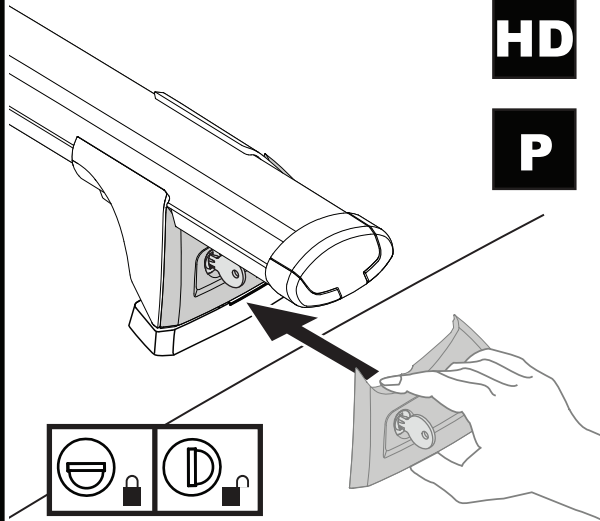

F

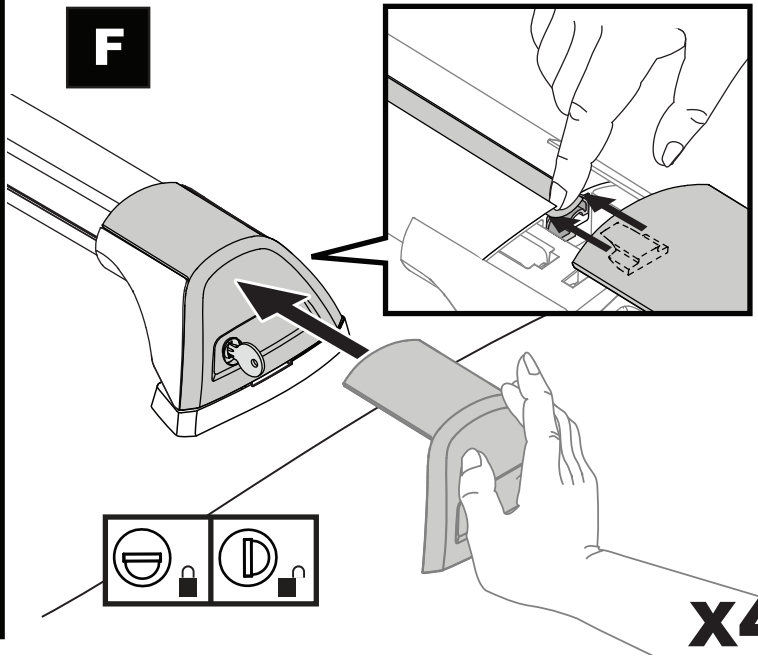

x4

17



x4

**ATTENTION • ACHTUNG • ATENCIÓN • ATTENTION • OPPMERKSOMHET • ATENÇÃO • ВНИМАНИЕ • ATTENZIONE
 UWAGA • UPOZORNĚNÍ • UPOZORNENIE • LET OP • UPPMÄRKSAMHET • OPMÆRKSOMHED • УВАГА • HUOMIO**

- EN** Please read safety and warranty booklet included with this product prior to use. For more information visit your local dealer.
- DE** Bitte lesen und beachten Sie die beiliegende Montageanleitung, Sicherheitshinweise und Garantiebedingungen bevor Sie das Produkt montieren/benutzen. Für weitere Informationen kontaktieren Sie bitte Ihren Händler.
- ES** Por favor, lea folleto de seguridad y garantía que se incluye con este producto antes de su uso. Para obtener más información, visite a su distribuidor local.
- FR** Veuillez lire attentivement le manuel de sécurité et de garantie avant utilisation. Pour plus d'informations, visitez votre concessionnaire local.
- NO** Vennligst les hefte om sikkerhet og garanti som er vedlagt dette produkt før det tas i bruk. For mer informasjon ta kontakt med din forhandler.
- PT** Por favor leia o manual de segurança e garantia incluído, antes de utilizar o produto. Para mais informações visite o seu revendedor local.
- RU** Пожалуйста, ознакомьтесь с инструкцией перед тем, как использовать товар. Для получения более подробной информации обратитесь к местному дилеру.
- IT** Si prega di leggere il libretto di sicurezza e garanzia incluso nel prodotto prima dell'uso. Per maggiori informazioni visita il rivenditore locale.
- PL** Proszę zapoznać się z warunkami gwarancji i bezpieczeństwa przed użyciem produktu. W celu uzyskania dodatkowych informacji proszę kontaktować się z najbliższym autoryzowanym punktem sprzedaży.
- CS** Před použitím si prosím přečtete přiložené informace o bezpečnosti a záručních podmínkách. Pro více informací navštivte nejbližšího dealera.
- SK** Pred použitím si prosím prečítajte priložené informácie o bezpečnosti a záručných podmienkach. Pre viac informácií navštívte najbližšieho diera.
- NL** A.U.B. bijgesloten garantie- en veiligheidsinstructies grondig lezen voor gebruik van dit product. Voor meer informatie graag contact opnemen met uw dealer.
- SV** Var snäll och läs igenom säkerhets- och garantihäftet som medföljer produkten före användning. För mer information besök din lokala återförsäljare.
- DK** Læs venligst sikkerheds- og garantibogholderen, der følger med dette produkt, inden brug. For mere information besøg din lokale forhandler.
- UA** Будь ласка, ознайомтеся з броюньо безпеки та гарантії, включені до цього продукту перед використанням. Для отримання додаткової інформації відвідайте місцевого дилера.
- FI** Lue tämän tuotteen mukana toimitetut turvallisuus- ja takuu huoltopalvelut ennen käyttöä. Lisätietoja saat paikalliselta jälleenmyyjältä.

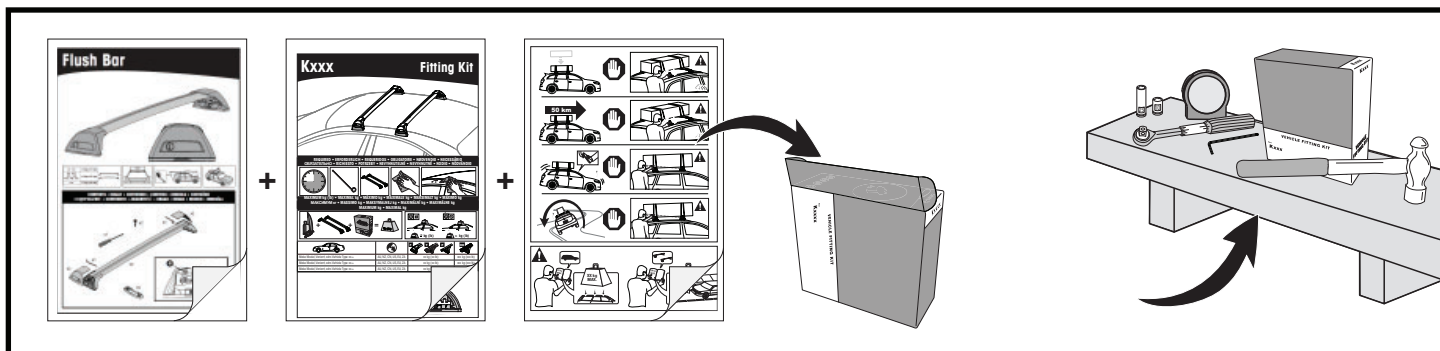
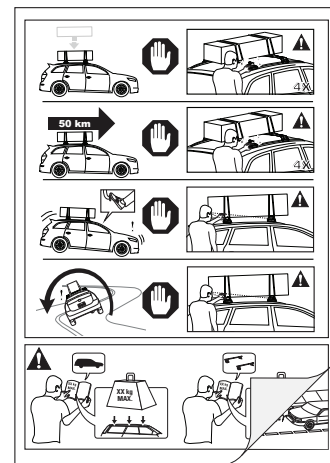

**REMOVAL • ABMONTIEREN • DESMONTAJE • DÉPOSE • FJERNING • REMOÇÃO • УДАЛЕНИЕ
 SMONTAGGIO • USUNIĘCIE • ODSTRANĚNÍ • ODSTRÁNENIE • VERWIJDERING • AVMONTERING**

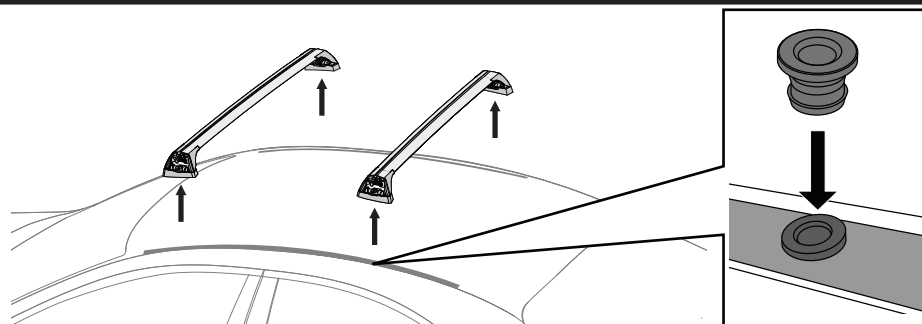

x4

Yakima Australia Pty Ltd
 17 Hinkler Court, Brendale
 QLD 4500, Australia
 1800 143 548
www.prorack.com.au
www.whispbar.com.au

Yakima Europe Coöperatief U.A.
 Twentehaven 7, 3433
 PT Nieuwegein, The Netherlands
 +31 2080 81425
www.prorackeurope.eu
www.yakima.eu

Yakima Products, Inc.
 4101 Kruse Way
 Lake Oswego, OR. 97035 USA
 888 925 4621
www.yakima.com

WORKS WITH:
YAKIMA
 WHISPBAR
PRORACK